

Ax350i – Unique Serialisation

Our goal is to provide you with the best fit for the coding requirements in your production. The **Ax350i** ink jet printer delivers high quality codes, in almost any environment, and on virtually any surface. The clear, readable text is coded at high production line speeds, using Domino developed inks which ensure compliance to local regulations.

The **Ax350i** delivers low cost of ownership by decreasing consumable use during production runs, and removing regular service intervals. Maintenance of the printer is reduced to 10 minutes per year.

The **Ax350i** - Unique Serialisation option operates with Domino's Editor GT and Supertracker controller solutions to support promotional coding applications.



Maximum uptime on production lines

- ◆ A flexible modular design, sealed IP66 electronics enclosure, dynamic on-board monitoring and control enable easy line integration and excellent prints, even in harsh environments.
- ◆ The **Ax350i** is service-free; only the **iTechx** module (ITM) needs to be replaced once annually, which is a less-than-ten-minute operator task.
- ◆ Operates with Domino's Editor GT and Supertracker controller solutions to manage code security, removing the risk of printing duplicate printed codes.



i-Pulse printhead technology

- ◆ Printheads start up first time, even after extended shutdowns thanks to Domino's unique nozzle-sealing technology.
- ◆ Best readability and reliability at faster speed in a higher 9-drop resolution (versus traditional 7 drops), plus up to 24% less ink usage resulting from optimised ink drop formation.
- ◆ Available in 60um for 50um print head to support small, precise coding when required.

Consistent quality codes

- ◆ Domino supplies a range of inks manufactured to GMP (Good Manufacturing Practice) which are compliant with leading global legislation for food packaging.
- ◆ Our inks offer lasting adhesion, lightfastness and high contrast, even on difficult substrates (e.g. polyolefins) and after harsh post-print processes.
- ◆ Environmental-friendly options, reduced ink consumption, optimised packaging and fully-depleting cartridges reduce waste and ecological footprint.

www.domino-printing.com



A complete solution



Our services are designed to provide operational insight so you can eliminate downtime and maximise production efficiency

Operational support

An outstanding level of care, wherever you are. Our **SafeGuard** packages provide high-quality, on-site assistance and AR-enabled remote guidance from our engineers. **SafeGuard** helps to ensure we can be with you when you need us most.

Automatic code inspection

Ensure every code that leaves your factory is present and correct, and free up operator time. With the R-Series, Domino's range of vision control systems, you can automate your code inspection to validate code presence, placement, and readability.

Utilise your current control software

There is no need to retrain line operators. The **Ax350i** can integrate with existing Domino control software (Editor GT / Supertracker).

Reduced running costs

The **Ax350i** reduces the consumables use through optimisation of ink drop size, and reduction of solvent consumption. The overall cost of ownership can be reduced by up to 30%*.

*ink type dependent.

Technical specification Ax350i

Printing Specification	
Printhead nozzles	50µm 60µm
Speed – 1 line, 5 dot characters(m/s)*	5.9 7.1
Dot size(mm)**	0.26 0.31
Print heights (single print head) Supported code formats	Up to 32 dots/20mm full unicode support text
Ownership Specification	
User interface	10.4" touch screen options
Conduit length	3m & 6m options
Printhead type	Straight
Software	QuickStep 3
Comms ports	Cabinet USB port (x1); Ethernet RJ45 port (x1)
Printer status monitoring	4 stage beacon output (x1); 3 stage alarm output (x1)
Cartridge replacement (Ink and make-up)	Auto recognition; 20 second operator task; no line stop required
Servicing – ITM replacement	Sub 10 minute operator task; line stop required
Service interval***	Typically every 12 months
Material	304 steel, IP55 cabinet; IP66 electronics enclosure
Consumables****	
Inks	Wide range of black and coloured inks including options for food packaging, industrial, UV-fluorescent
Ink cartridge volume	825ml
Make-up cartridge volume	1200ml
Standard Configuration	
Extended comms pack	Cabinet USB port (x1); control port (x1); touchscreen / ethernet port (x1)
RS232 pack	RS232 port (x1)
Extended I/O pack	I/O - 12 inputs / 6 outputs (x1)

* Speed quoted at the following characters per inch 60µm = 10 characters. 50µm = 14 characters
 ** Dots size may vary depending on substrate type *** Dependant on ink type and ITM choice
 **** This product has a Quality Management System that means that it will only work with Domino circuitry, and it uses dynamic security measures to block non-Domino circuitry from being used. From time to time updates to the circuitry will be issued by Domino to maintain the effectiveness of the Quality Management System.

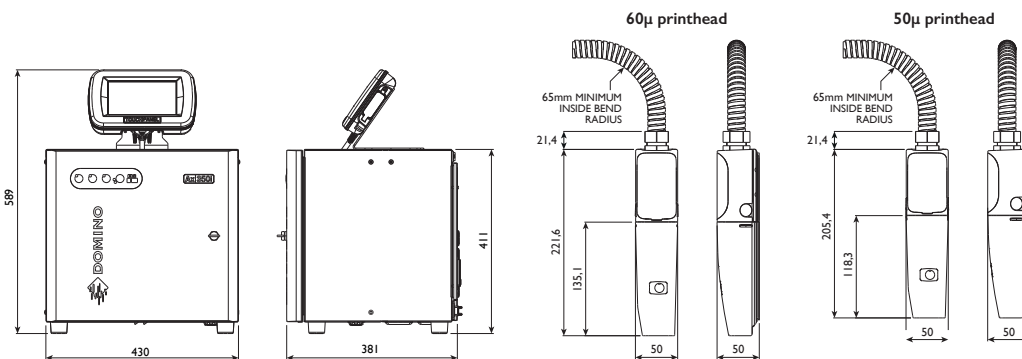

Multi Line

1234 MULTI LINE 12/03/25
00:00 PM
ABC12345

AB4TYFDRT33
BB4TYFDRT44



TALK TO AN EXPERT

Contact details: enquiries@domino-uk.com
Telephone: +44 1954 782 056
Website: www.domino-printing.com