



DPX Fume Extraction Systems Product Manual

DPX350

DOMINO

This manual, Domino Part No. EPT061670, has been produced for use in the maintenance and operation of the Domino DPX350 Fume Extraction System.

© Domino Printing Sciences plc. 2025.

All rights reserved. No part of this publication may be reproduced, stored on a retrieval system, or transmitted in any form, or by any means, electronic, mechanical, photocopying, recording or otherwise, without the prior permission of Domino UK.

Domino UK has a policy of continuous product improvement. The Company, therefore, reserves the right to modify the specification contained in this manual without notice.

For sales and service assistance, please contact your local Domino Distributor, or:

Domino UK

Bar Hill

Cambridge CB23 8TU

United Kingdom

Tel: +44 1954 782551

Fax: +44 1954 782874

AMENDMENT RECORD

Amendment	Date
All parts at Issue 1	June 2020
All parts at Issue 2	November 2020
All parts at Issue 3	April 2021
All parts at Issue 4	October 2024
All parts at Issue 5	November 2024
All parts at Issue 5	July 2025

PREFACE

This product manual, Domino Part No. EPT061670, is for use in the operation and maintenance of DPX350 fume extraction systems by operators and to reinforce and complement any training program available with the product. It is not designed to replace any such training program.

This product manual is the official authority for the operation and maintenance of DPX350 fume extraction systems. It is the source document for all translated versions. It is the “Original Instructions” for the purposes of the Machinery Directive.



DPX350

Only engineers trained and certified by Domino should carry out repairs. Genuine Domino parts must always be used to ensure quality and performance.

Users of this equipment are warned that it is essential to read, understand and act according to the information given in this product manual. The product manual also specifies a set of symbols which are used elsewhere in the product manual and on the product to convey special warnings or requirements. It is, therefore, essential that users are also familiar with these symbols and act accordingly.

DPX FUME EXTRACTION SYSTEMS

CONTENTS

	Page
PREFACE	3
WARNINGS, CAUTIONS AND NOTES	5
WARNING AND CAUTION SYMBOLS.....	5
DPX350 WARNING AND CAUTION LABEL.....	6
GENERAL WARNINGS AND CAUTIONS.....	7
INTRODUCTION	9
SPECIFICATION.....	10
DPX350.....	11
OPERATION	13
CONTROL PANEL.....	13
On Off Button	13
Alarm	13
Speed Control	13
INSTALLATION	15
INSTALLATION WARNING	15
SITE REQUIREMENTS.....	15
ELECTRICAL CONNECTIONS.....	16
Power Socket.....	17
Interface Socket Wiring	18
HOSE SYSTEM.....	20
Best Practice for Fire Risk Minimisation.....	22
MAINTENANCE	23
RECOMMENDED ROUTINE MAINTENANCE.....	24
Daily.....	24
Weekly.....	24
Monthly.....	24
6 Monthly.....	24
Example of a Maintenance Schedule:.....	25
HOW TO EMPTY A HOSE.....	26
CHANGING THE PRE-FILTER	27
CHANGING THE HEPA MAIN FILTER.....	28
CHANGING THE CARBON MAIN FILTER	30
TROUBLESHOOTING	33

WARNINGS, CAUTIONS AND NOTES

The warnings, cautions and notes used throughout this product manual are highlighted by the use of international hazard symbols. The following definitions for all three of these notices are described below in the format they are presented in this product manual.

WARNING: A hazard that may cause death or injury.	
	

CAUTION: A hazard that may cause damage to equipment or the environment.	
	

Note: Important additional information.

WARNING AND CAUTION SYMBOLS

The symbols below are used to highlight specific warnings and cautions.



Warning or Caution, read and comply with the warning or caution text to avoid physical injury, damage to equipment or damage to the environment.



Risk of fire by igniting flammable material.



Risk of coming into contact with electricity.



Eye protection must be worn.



Protective gloves must be worn.



A protective face mask must be worn.



Heavy object. Two people are required to lift.



Read the instructions.



DPX350 WARNING AND CAUTION LABEL

The image below illustrates the warning and caution label that is fixed to the DPX350 cabinet.



GENERAL WARNINGS AND CAUTIONS

WARNING: Flammable material. Risk of fire.	
	<p>Remove any debris from the area around the laser beam. Inspect the area around the hose (including edges and welded seams of the extraction nozzle) as specified in “RECOMMENDED ROUTINE MAINTENANCE” on page 24.</p>

WARNING: Harmful substance. Risk of personal injury	
	<p>Set up the DPX carefully to extract fumes & particulates. Operate it in a well ventilated environment. Carry out a risk assessment and implement the necessary additional controls to meet local and national safety regulations.</p> <p>Take particular care when changing any parameters of the laser process. These may change the requirements of the filtration, for example:</p> <ul style="list-style-type: none"> • Different substrates being lasered • Laser outputs/volumes • Air circulation/ventilation.
	<p>Wear Personal Protective Equipment (PPE) as identified during your risk assessment, when changing filters.</p> <p>Do not operate the equipment without the filters installed.</p>

WARNING: Heavy equipment. Risk of personal injury	
	<p>Carry out a risk assessment before moving the equipment. Do not lift the equipment by yourself.</p>

CAUTION: <i>Risk of damage to equipment.</i>	
	<p>Follow the recommended routine maintenance schedule (given later in this manual). A good level of housekeeping will promote serviceability and reduce downtime.</p> <p>Consult local regulations concerning fume extraction systems, as these may be subject to periodic checks by authorised agencies and the re-issue of certificates of compliance, or equivalent.</p> <p>Do not operate the DPX350 outside or in wet environments.</p>

THIS PAGE INTENTIONALLY LEFT BLANK

INTRODUCTION

The DPX fume extraction system takes fumes and particulates, generated by the laser beam on the substrate, away from the head of the laser. This keeps the environment around the laser head cleaner and maintains the performance of the laser system.

It is the responsibility of the user of the DPX to carry out a risk assessment that ensures local regulations (on the provision of work equipment to employees) are complied with. Risk assessments should be carried out whenever anything changes and must take into consideration factors such as: the substrate, laser power, air circulation, ventilation and factors that may affect filter efficiency.

The DPX displays an alert if a filter is blocked. The machine control system will indicate when the filter replacement is due.

The cabinet is fully mobile on lockable, high strength, corrosion resistant castors.

The filter system, consists of:

- A pre-filter (F8 pleat).
- A HEPA H14 filter.
- An activated carbon filter.

SPECIFICATION

Airflow (maximum):	400m ³ /h
Power Supply:	100-230 Vac, 50Hz/50Hz, 1.1kw
Controls/Information:	Illuminated On/Off Switch New filter alarm indicator Speed control dial
Sound Rating:	< 60dBA
Cabinet size:	H 630mm (24.8in) W 370mm (14.5in) D 520mm (20.5in)
Cabinet:	37 kg (81.57 lbs)
Filters:	Pre-filter - F8 Pleat Main Filter Stage 1 - H14 HEPA Main Filter Stage 2 - Activated Carbon
Hose:	50mm x 2m (2in. x 6.5ft)
Operating temperature:	5 - 45°C
Operating Humidity:	10 - 90% non-condensing
Cabinet Construction:	Mild Steel

DPX350

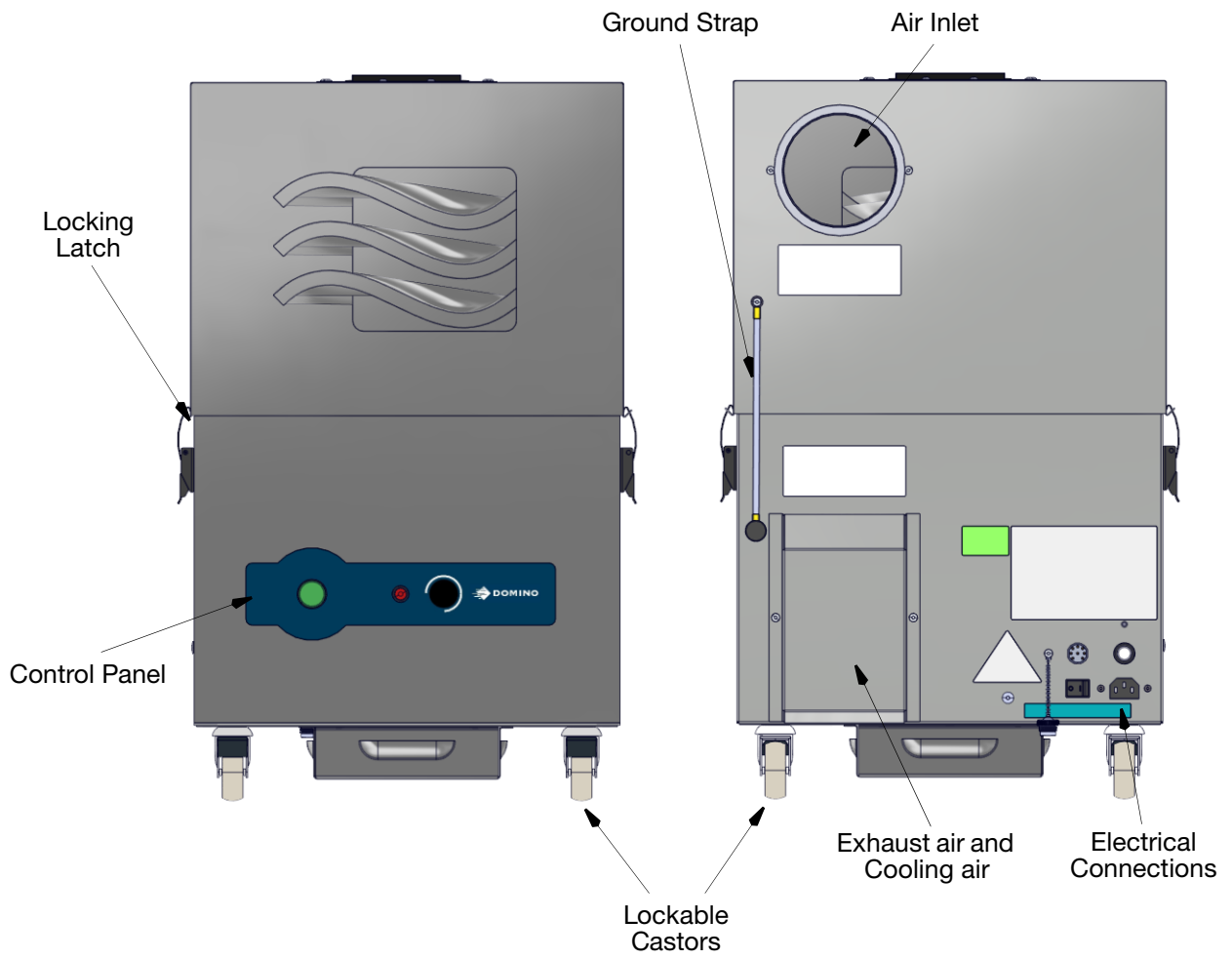

DPX350

THIS PAGE INTENTIONALLY LEFT BLANK

OPERATION

CONTROL PANEL

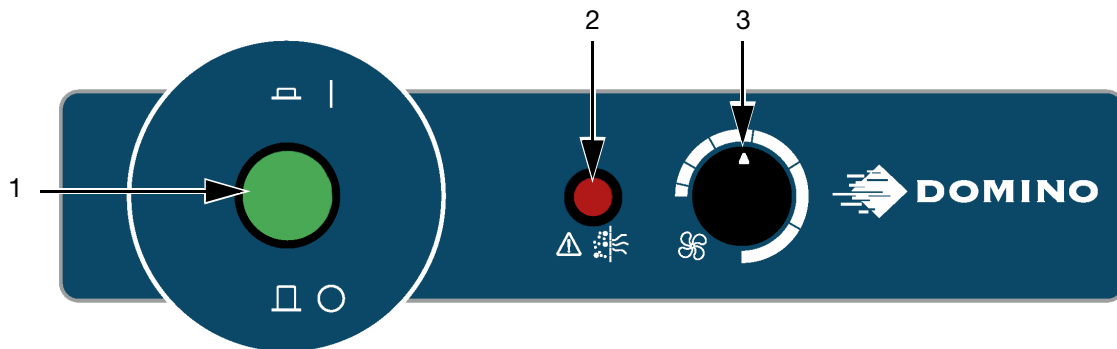

- (1) Illuminated On/Off Button
- (2) New Filter Alarm Indicator
- (3) Speed Control Dial

Control Panel - Controls and Indicators

On Off Button

The On/Off button (1) will illuminate green when the unit is on.

Alarm

The control system actively monitors the airflow through the particle filters, the red alarm indicator (2) will illuminate when new filters are required.

Speed Control

To increase the vacuum, turn the speed control dial (3) clockwise. Turn the control anti-clockwise to reduce the vacuum.

Use the lowest speed possible, to make sure fumes are drawn into the extraction nozzle without triggering the alarm. Setting the speed too high will reduce the filter life.

THIS PAGE INTENTIONALLY LEFT BLANK

INSTALLATION

INSTALLATION WARNING

WARNING:	Flammable material. Risk of fire
	Paper label and small cardboard applications that are at risk of being drawn into the extractor, must be fitted with a spark arrestor device unless the production line risk assessment indicates otherwise.

SITE REQUIREMENTS

The fume extractor should be as near to the laser head as possible. The following floor area and access is required:

- Front of cabinet - for operator control and maintenance access.
- Rear of cabinet - for hose system and electrical connection.
- Sides of cabinet - for access to latches and filter replacement.
- Power connection - to remove the plug in case there is a need for urgent disconnection.

Once in position, lock the two front castors.

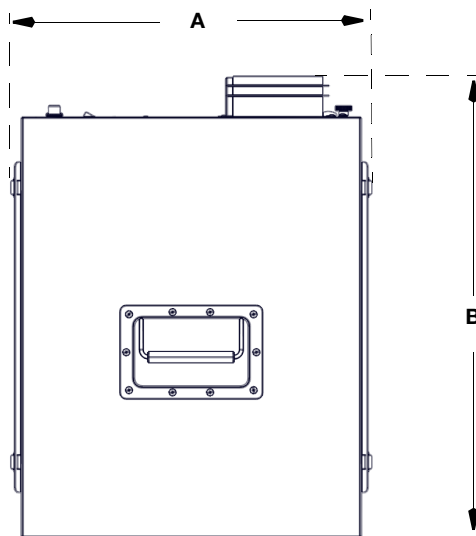

Note: 220mm clearance required for hose attachment on rear side. (See also the dimensions on [page 10](#)).

	DPX350
A	370mm
B	520mm

ELECTRICAL CONNECTIONS

Before connecting the power supply, make sure that the voltage, frequency and power requirements are correct as shown on the label attached to the cabinet rear.

CAUTION: <i>Electricity. Risk of damage to the printer.</i>	
	<p>Do not exceed the voltage, frequency or power requirements, as shown on the label on the cabinet rear.</p> <p>Make sure the power plug is accessible in case there is a need for urgent disconnection.</p> <p>Use a suitably rated and approved power supply cable/cord-set, in accordance with the regulations of the country it is used in.</p>

It is important that the local power supply is protected by a circuit breaker of the correct rating, and that the cabling and plug type used are suitably rated.

Refit the ground strap shown in the illustration below, after doing any maintenance work.

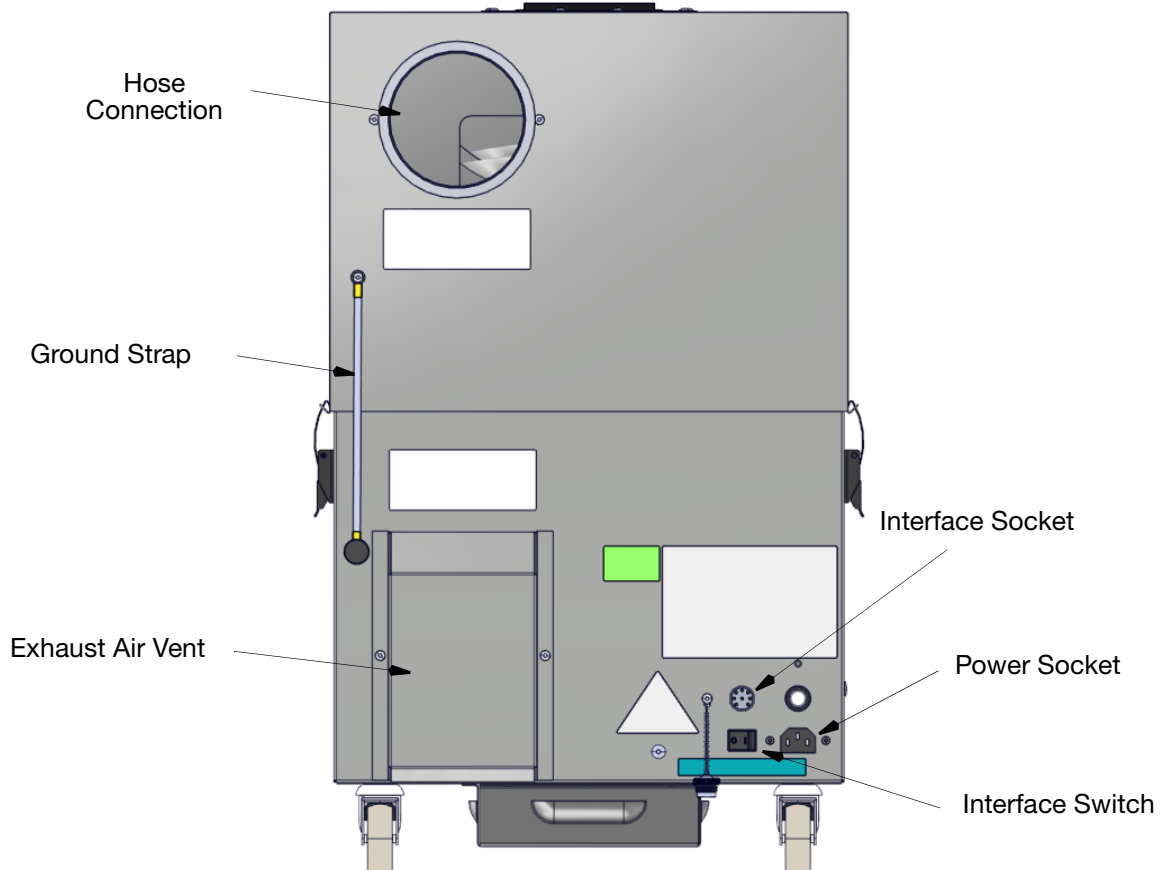

DPX350 Fume Extractor Cabinet - Rear View

Power Socket

Connect the power cable provided to this socket.

<i>CAUTION: Electricity. Risk of damage to the printer.</i>	
	<p>Do not exceed the voltage, frequency or power requirements, shown on the label on the rear of the cabinet.</p> <p>Make sure the power plug is accessible in case there is a need for urgent disconnection.</p> <p>Use an appropriately rated and approved power supply cable/cord-set, in accordance with the regulations of the country it is used in.</p>

Interface Socket Wiring

The DPX350 fume extractor has an 8-way Lumberg interface socket at the rear panel to provide remote On/Off switching and status feedback.

To enable interfacing, set the interface switch to '1'. Unscrew the interface socket cap and plug in the interface cable or a remote ON/OFF switch. Connect the other end of the interface cable to the laser coder.

If the interface socket is not used, protect the socket by fitting the screw-on cap. Set the interface switch to '0', or the fume extractor will not work.

Connect the DPX fume extraction system to the mains electricity supply, before it is switched on by the laser using the interface cable. If the mains electricity supply is not connected, the fume extractor will not work.

D310-Series Interface Wiring Diagram

Use the correct Domino interface cable EPT065389 (supplied with the DPX350), to connect the fume extractor to the D310-Series laser coder. This cable has a connector for the DPX350 and an open end for the D310-Series GPIO connector.

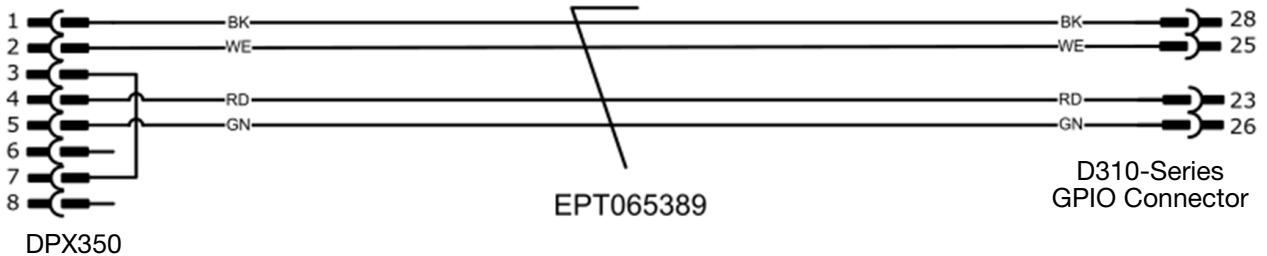

8-Way, Male,
Lumberg
View from Solder
Side

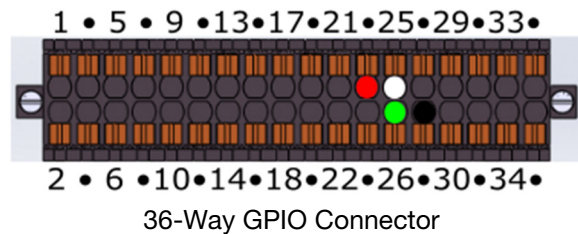

36-Way GPIO Connector

D-Series or F-Series Interface Wiring Diagram

Use the correct Domino interface cable EPT065389 (supplied with the DPX350), to connect the fume extractor to the D-Series or F-Series.

- This cable has a connector for the DPX350 and an open end for the D/F-Series.
- Use the 6-way Lumberg connector supplied with the D/F-Series.
- Do not use the interface cable L050025 with the DPX350. The internal wiring is different. If cable L050025 is used, damage may be made to the DPX350 and the D/F-Series.

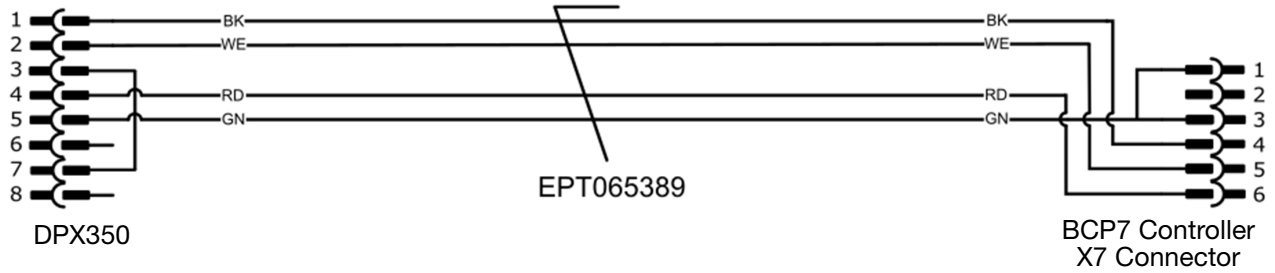

8-Way, Male,
Lumberg
View from Solder
Side



6-Way, Female,
Lumberg
View from Solder
Side

HOSE SYSTEM

WARNING: Flammable material. Risk of fire.	
	<p>Remove any debris from the area around the laser beam. Inspect the area around the hose (including edges and welded seams of the extraction nozzle) as specified in “RECOMMENDED ROUTINE MAINTENANCE” on page 24.</p>

The normal hose connection between the printing location and the extractor cabinet air inlet is by a 50mm (2”) flexible hose. The flexible hose is supplied with the extractor. At the extractor cabinet end, the hose is a push-fit onto the inlet connection. The following guidelines should be applied at the laser head end:

- Install the extraction nozzle downstream of the marking process location, to ensure that fumes are transported in the direction of the extraction nozzle.

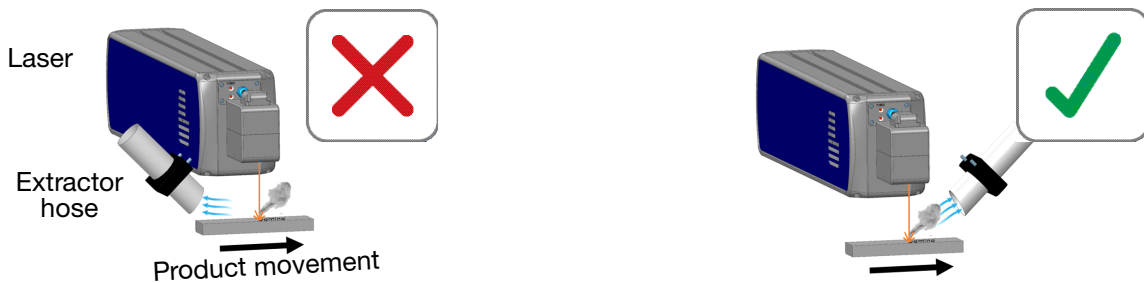

Incorrect nozzle position - fumes being drawn along with the product movement away from the nozzle

Correct nozzle position - fumes being drawn along with the product movement into the nozzle

- Ensure that the air supply to the laser head lens is not too strong as to blow fumes away from the extraction hose inlet.

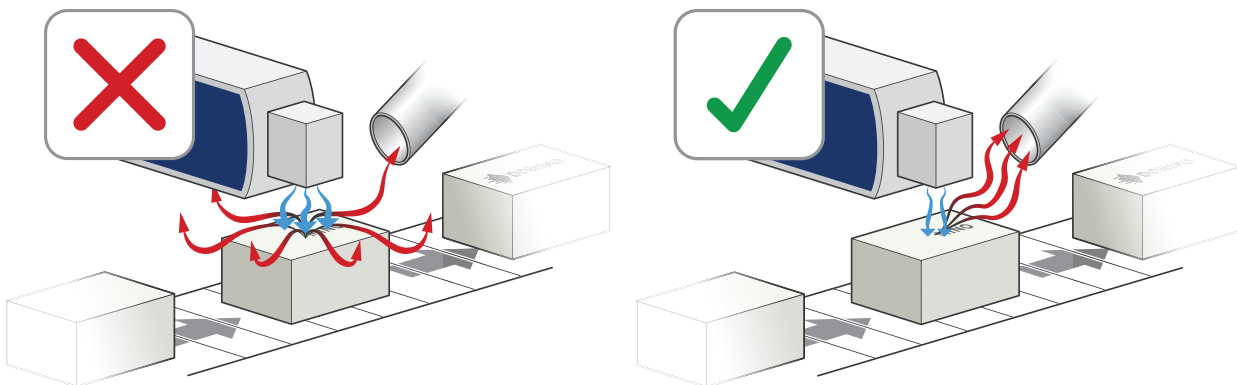

Incorrect lens air (too strong) - fumes being blown away from extractor hose inlet

Correct lens air - fumes being drawn into extractor hose inlet

When the final position of the Fume Extractor and extractor hose is established, the hose should be routed to have a minimum number of bends.

Special extraction enclosures may be required for optimum performance, contact a local Domino distributor for assistance.

WARNING: Flammable material. Risk of fire.	
	<p>Installations must be such that they avoid hot particle build up on host machine parts or nozzle edges located close to the air flow inlet opening (extraction nozzle).</p> <p>It is possible for the build up to break off and enter the extraction unit; where the build up is hot, it can ignite the dust in the DPX.</p>

If incorrectly setup and maintained, particle collections can build up, forming lumps of debris. In high production rate applications and/or with some materials, these lumps may be hot.

If the debris lumps get large enough, they may break free and enter the extraction nozzle where, if hot enough, they could ignite the dust within the pre-filter.

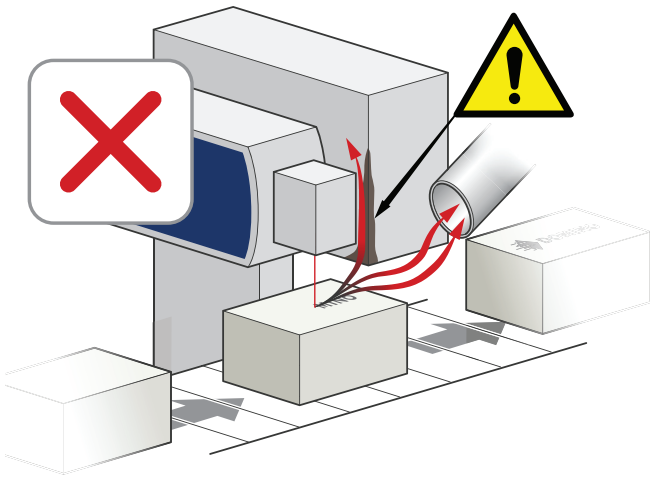

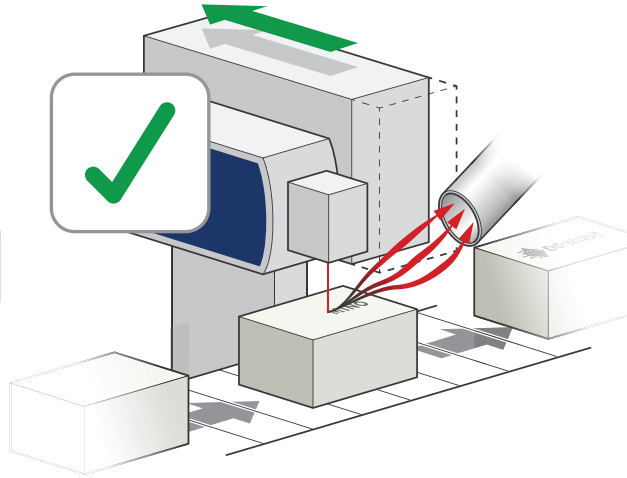

Incorrect machine part blocking fume path - build up of debris



Correct machine part out of fume path - no build of debris

Best Practice for Fire Risk Minimisation

WARNING: Flammable material. Risk of fire	
	<p>Paper label and small cardboard applications that are at risk of being drawn into the extractor, must be fitted with a spark arrestor device unless the production line risk assessment indicates otherwise.</p>

WARNING: Flammable material. Risk of fire	
	<p>Carry out the following recommendations. Smouldering debris can be drawn from the laser head into the DPX. This represents a fire risk. The practices detailed below, will reduce that risk.</p>

- Carry out a risk assessment for your installation.
- Implement maintenance checks at the appropriate frequency ([“RECOMMENDED ROUTINE MAINTENANCE” on page 24](#)). Increased inspection, based on risk assessment by the user, may be required in certain high volume and dusty applications.
- Carry out a new risk assessment as soon as anything is changed on the product line or the product itself (e.g. volume throughput, substrate, any guarding/shroud, etc.).
- Establish an appropriate regime for inspecting and cleaning the extraction hose and filters based on risk assessment by the user and the guidance contained in this manual.
- Ensure that flammable vapours (such as solvent vapours) are not present in the area. Solvents may be used for cleaning or other operations in the area. Make an assessment of the fire risk if they may be present. Consider all sources of ignition, including the laser head, electrical equipment and instrumentation. Eliminate the flammable vapours using good housekeeping techniques (clean up any spillages and dispose of any tissues in accordance with local regulations).
- Ensure that the substrates used are appropriate for the laser and the extraction unit. This should be specified and recorded. Any variation from this specification should be assessed for fire hazards, e.g. due to more dust creation and therefore potential dust and/or debris build-ups in the extracting area.
- Ensure that the Fume Extraction system operates correctly with adequate extraction when the laser is in use. Use either an interlock or an operating procedure together with appropriate training for operators. The extraction must be strong enough to remove dust efficiently from the area of the laser head. It must not be so strong as to disturb the marking process.
- The extraction hose should be as short and straight as possible with minimum gentle curves. This helps avoid the build-up of combustible material in the hose.
- Prevent the build-up of dust on sharp edges and corners. Individual dust particles are unlikely to cause ignition but an accumulation of dust may. If dust does accumulate, then the extraction setup must be assessed and modified by the user to reduce dust build-up.
- Consider the risk of fire in a final risk evaluation and install adequate procedures.
- Establish appropriate training for operators. Training for laser printing and/or the production line must include the fire risk and appropriate response to a fire. Establish an appropriate regime of refresher training.

MAINTENANCE

WARNING: Flammable material. Risk of fire.	
	<p>Installations must be such that they avoid hot particle build up on host machine parts or nozzle edges located close to the air flow inlet opening (extraction nozzle).</p> <p>It is possible for the build up to break off and enter the extraction unit. If the build up is hot, it can ignite the dust in the DPX unit.</p> <p>Remove debris from the lasing process.</p> <p>Inspect the area around the hose (including edges and welded seams of the extraction nozzle) as specified in “RECOMMENDED ROUTINE MAINTENANCE” on page 24.</p>

WARNING: Harmful substance. Risk of personal injury	
	<p>Wear Personal Protective Equipment (PPE) as identified during your risk assessment, when working on the equipment and when changing filters.</p> <p>Obey local waste disposal regulations to dispose of used filters.</p>

WARNING: Heavy equipment. Risk of personal injury	
	<p>Carry out a risk assessment before moving the equipment.</p> <p>The main filter is heavy.</p> <p>Do not lift the equipment by yourself.</p>

- Notes: (1) The DPX has visual alarms: refer to [“TROUBLESHOOTING”](#) on page 33.
- (2) Instruction sheets are provided with each filter exchange kit, not in this manual.
- (3) Check the following for debris build-up at least daily, but more frequently depending upon production rate and laser power applied:
- Extraction nozzle
 - Flexible hose
 - Air inlet
- (4) The filter exchange kit includes instructions and a polythene bag with tie for filter disposal. Protective goggles, mask and gloves are not included in the filter exchange kit.

RECOMMENDED ROUTINE MAINTENANCE

The User's own risk assessment of the laser equipment setup, the materials being lasered and any changes to the setup, plus their experience of local conditions (e.g. dust build up) must be used to create a preventative maintenance and replacement schedule.

Due to the local variations that may be present in any particular laser application, the following Daily, Weekly, Monthly, Annual frequencies are for guidance only and must be backed up by local risk assessment and experience.

Daily

Check the following for debris build-up:

- Extraction nozzle
- Flexible hose
- Air inlet

Visually check for and remove any debris that might have built up in the extractor hose nozzle and (if fitted) the shroud, see ["HOW TO EMPTY A HOSE" on page 26](#).

Visually check that fumes are being drawn into the extractor. See ["HOSE SYSTEM" on page 20](#).

The laser marking application may require checks more frequently, depending upon the substrate quality, the marking rate and laser power applied.

Weekly

As Daily above, plus:

Check if the filters are showing signs of blockage or saturation. See ["CHANGING THE PRE-FILTER" on page 27](#).

Check hose and nozzle to ensure there is no blockage See ["HOSE SYSTEM" on page 20](#).

Monthly

As Weekly, plus:

Check the exhaust of the extraction unit to determine if any odours are passing through the filter system undetected.

Check the exhaust from the extraction unit to see if there is any sign of dust carry over. See ["HOSE SYSTEM" on page 20](#).

6 Monthly

As Monthly, plus:

Change the filters. See ["CHANGING THE PRE-FILTER" on page 27](#), ["CHANGING THE HEPA MAIN FILTER" on page 28](#) and ["CHANGING THE CARBON MAIN FILTER" on page 30](#).

Example of a Maintenance Schedule:

Activity	Interval		
	D	W	M
Extraction nozzle Removal of debris build-ups onto the nozzle or within the extraction area	x		
Extraction nozzle and hose Check correct installation condition and that all fumes are being drawn into the nozzle	x		
Check and Clean Lens Check correct positioning of extraction nozzle to ensure it has not been moved dangerously close to the position of the laser marking area	x		
Extraction unit display status Check the display status of the control panel		x	
Extraction unit setup Check extraction unit setup to see if required airflow is maintained		x	
Filters Check if the filters are showing signs of blockage or saturation		x	
Extraction nozzle and hose Check hose and nozzle to ensure there is no blockage		x	
Exhaust of the extraction unit Check the exhaust of the extraction unit to determine if any odours are passing through the filter system undetected			x
Exhaust of the extraction unit Check the exhaust from the extraction unit to see if there is any sign of dust carry over			x
Filters Change pre filter, HEPA filter and carbon filter	At least 6 monthly		

D = daily W = weekly M = monthly

Note:

Ignored maintenance can:

- increase the likelihood of causing a fire in the filter
- result in production line downtime
- result bad or unreadable codes
- loss of filtration.

HOW TO EMPTY A HOSE

In order to remove any dust deposits in the hose, we recommend to tap the hose while the extraction unit is running. If possible, position the hose in such a way that a gradient is created in the direction of the extraction, so detached dust residues can be sucked into the pre-filter.

Never tap out or empty the hose outdoors!

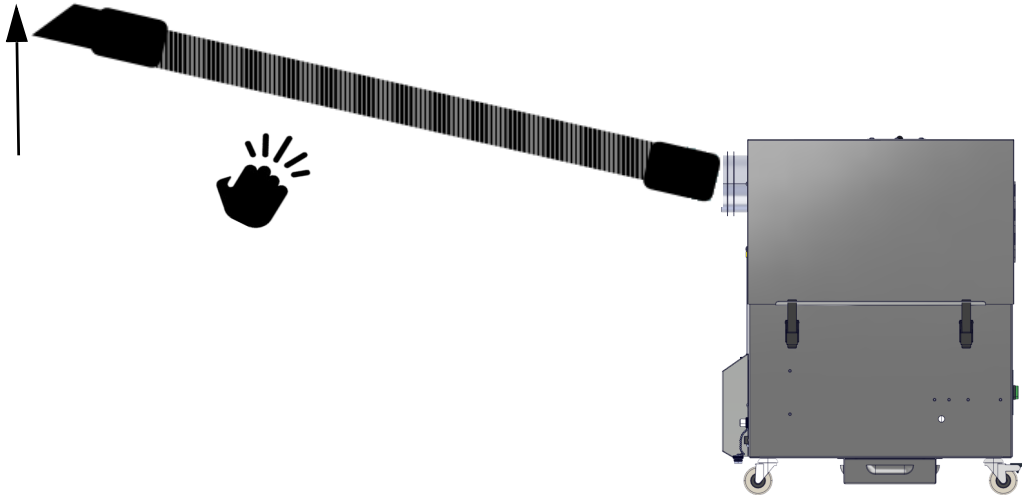

CHANGING THE PRE-FILTER

WARNING: Harmful substance. Risk of personal injury	
	<p>Wear protective gloves, mask and eyewear. Obey local waste disposal regulations to dispose of used filters.</p>

Note: Filter alerts may be caused by debris build up in the extraction nozzle, hose or air inlet. Check that these areas are free from debris before changing the filter.

The pre-filter is situated in the HEPA filter casing.

To change the pre-filter:

- (1) Turn off the DPX fume extractor.
- (2) Make-sure the wheel/castor locks are on.
- (3) Undo the four latches on the sides of the DPX, then remove the lid.

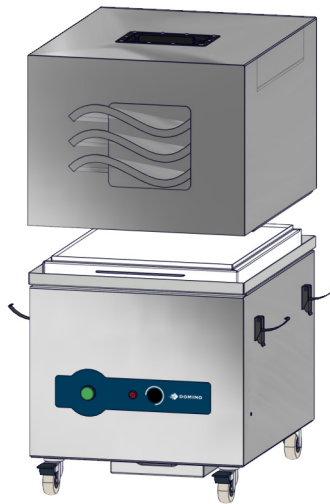

- (4) Remove the old pre-filter and place it in the bag provided.

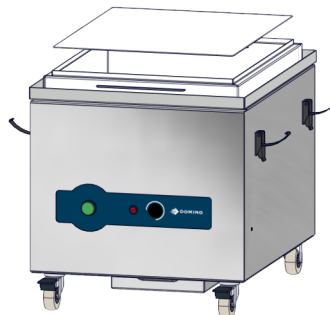

- (5) Clean and remove dust particles from inside the cabinet, before inserting the new filter.
- (6) Insert the new pre-filter, replace the lid and close the four latches.

CHANGING THE HEPA MAIN FILTER

WARNING: Harmful substance. Risk of personal injury	
	<p>Wear protective gloves, mask and eyewear. Obey local waste disposal regulations to dispose of used filters.</p>

- Notes: (1) Filter alerts may be caused by debris build up in the extraction nozzle, hose or air inlet. Check that these areas are free from debris before changing the filter.
- (2) It is recommended to change the pre-filter at the same time, unless it has already been changed recently.

To change the HEPA main filter:

- (1) Turn off the DPX fume extractor.
- (2) Make-sure the wheel/castor locks are on.
- (3) Undo the four latches on the sides of the DPX, then remove the lid.

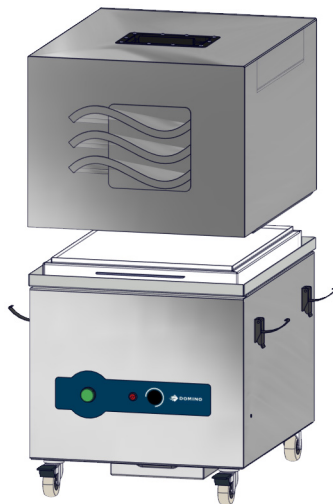

- (4) Remove the pre-filter.

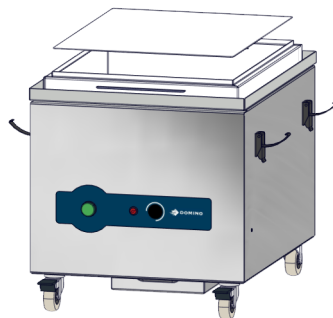

- (5) Lift the HEPA main filter off of the carbon filter, remove it and place it in the bag provided.



- (6) Clean and remove dust particles from inside the cabinet, before inserting the new filter.

- (7) Insert the new HEPA main filter and pre-filter.

Note: Make sure the HEPA filter sits correctly on top of the carbon filter.

- (8) Replace the lid and close the four latches.

CHANGING THE CARBON MAIN FILTER

WARNING: Harmful substance. Risk of personal injury	
	<p>Wear protective gloves, mask and eyewear. Obey local waste disposal regulations to dispose of used filters.</p>

- Notes: (1) Filter alerts may be caused by debris build up in the extraction nozzle, hose or air inlet. Check that these areas are free from debris before changing the filter.
- (2) It is recommended to changed the pre-filter unless it has already been changed recently.

To change the carbon main filter:

- (1) Turn off the DPX fume extractor.
- (2) Make-sure the wheel/castor locks are on.
- (3) Undo the four latches on the sides of the DPX, then remove the lid.

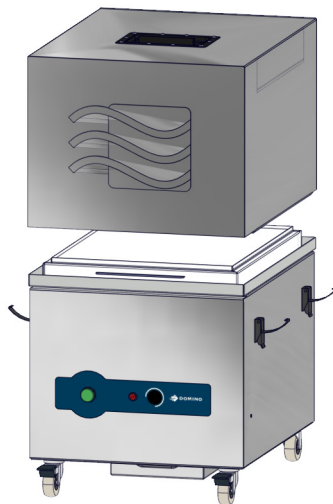

- (4) Remove the pre-filter.

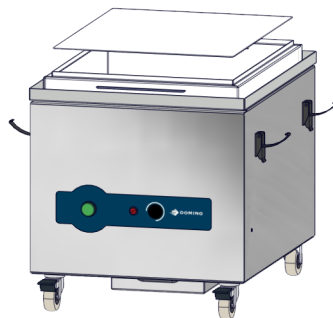

- (5) Lift the HEPA main filter off of the carbon filter and remove it. Also, remove the carbon filter. Place the old filters in the bag provided.



- (6) Insert the new carbon filter, HEPA filter and pre-filter.

- (7) Clean and remove dust particles from inside the cabinet, before inserting the new filter.

Note: Make sure the HEPA filter sits correctly on top of the carbon filter.

- (8) Replace the lid and close the four latches.

THIS PAGE INTENTIONALLY LEFT BLANK

TROUBLESHOOTING

Red LED ON	
<p>The pre-filter and/or main filter may be blocked.</p>	<p>Unless recently changed, replace the pre-filter and re-start the machine.</p> <p>If the red LED (or audible alarm) does not switch off, replace the HEPA filter.</p> <p>If these filters have been recently changed then another fault may be causing the LED to illuminate.</p>
Red LED continues after filters have been checked	
<p>The connecting hose may have a leak. Or, the vacuum sensor tubes in the air inlet may be blocked.</p>	<p>Check all hose, seals and connections for leaks. Check the vacuum sensor tube for blockages.</p>
<p>The alarm has triggered and the blower stops.</p>	<p>The thermal cut out on the blower may have engaged.</p> <p>Check the cooling vents both inside and out. Switch off mains power and allow the blower to cool. If this does not remedy the fault contact your supplier.</p>
Electrical Faults	
<p>Blower does not function or has developed a fault.</p>	<p>Procedure:</p> <ol style="list-style-type: none"> (1) Check all cables and connections inside and out. (2) Make sure the power supply matches the requirements of the machine. (3) Switch off main power, check all vents for blockages, allow motor to cool and restart. (4) An electrical part may need replacement, contact supplier.
<p>Control signal to/from interfaced equipment is incorrect or absent.</p>	
<p>LED is not illuminated.</p>	

Filter Faults	
Odour or particles in exhaust air.	The main filter may be damaged, fitted incorrectly or missing. Or, the chemical section of the main filter may be exhausted. Check main filters and replace if necessary.
Airflow insufficient to remove fume when the filter is not blocked.	Possible airflow leak or a blockage. Check all hose, seals and connections for leaks and check the vacuum sensor tube for blockage. If OK then increase airflow level.
The main filter has a shorter than expected life.	Large particles may be bypassing the pre-filter. Check the pre-filter which may be damaged or missing.



Domino DPX350 Fume Extraction System Product Manual

Domino Printing Sciences plc has a policy of continuous product improvement, the Company therefore reserves the right to modify the specification contained within this document without notice.

© Domino Printing Sciences plc 2025. All rights reserved.



For additional documentation, including other available languages, either scan the QR code, or go to <https://mydomino.domino-printing.com>

Domino UK Limited

Trafalgar Way
Bar Hill
Cambridge CB23 8TU
United Kingdom

Tel: +44 (0)1954 782551
Fax: +44 (0)1954 782874
Email: enquiries@domino-uk.com

Domino Amjet Inc.

1290 Lakeside Drive
Gurnee IL.60031
U.S.A.

Tel: +1 847 244 2501
Fax: +1 847 244 1421
Email: solutions@domino-na.com



EPT061670_6 English