

# F-Series User Guide

**F22 Ii**

**F320i**

**F520i**

**F720i**

# DOMINO

All rights reserved. No part of this publication may be reproduced, stored on a retrieval system, or transmitted in any form, or by any means, electronic, mechanical, photocopying, recording or otherwise, without the prior permission of Domino Printing Sciences plc.

Domino Printing Sciences plc. has a policy of continuous product improvement, the company therefore reserves the right to modify the specification contained in this User Guide without notice.

© Domino Printing Sciences plc. 2024.

For sales and service please contact:

[www.buydomino.com](http://www.buydomino.com)

[www.domino-printing.com](http://www.domino-printing.com)

## Domino UK Ltd.

Trafalgar Way  
Bar Hill  
Cambridge CB23 8TU  
United Kingdom  
Tel: +44 (0)1954 782551  
Fax: +44 (0)1954 782874

## Domino North America

1290 Lakeside Drive  
Gurnee IL.60031  
U.S.A.  
Tel: +1 847 244 2501  
Fax: +1 847 244 1421

# AMENDMENT RECORD

## Amendment

All parts at Issue 1  
All parts at Issue 2  
All parts at Issue 3  
All parts at Issue 4  
All parts at Issue 5

## Date

December 2020  
June 2022  
February 2023  
June 2023  
August 2024

## PREFACE

<b>WARNING:</b>	<b>Invisible Class 4 Laser Radiation. Risk of personal injury.</b>
	<p><b>Read the manual before and when operating this laser system.</b></p> <p>This product emits powerful invisible infrared laser radiation. A risk of personal injury or damage to equipment including fire may result if proper safety precautions are not obeyed.</p>

This manual EPT066750 is intended for use only with the following F-Series products:

F221i CP 10 STD	F520i 10 STD	F720i 10 STD
F221i CP 10 SHUTTER	F520i 10 STD SHUTTER	F720i 10 STD SHUTTER
F221i EP 10 STD	F520i 15 STD	F720i 15 STD
F221i EP 10 SHUTTER	F520i 15 STD SHUTTER	F720i 15 STD SHUTTER
F320i CP 10 STD	F520i CP 10 STD	F720i CP 10 STD
F320i CP 10 SHUTTER	F520i CP 10 STD SHUTTER	F720i CP 10 STD SHUTTER
	F520i EP 10 STD	F720i EP 10 STD
	F520i EP 10 STD SHUTTER	F720i EP 10 STD SHUTTER

## Preface

This manual has been produced for use in the operation of the Domino F-Series Laser Coder and to reinforce and complement any training program available with the product. It is not designed to replace any such training program.





For sales and service assistance please visit the following website and select “Contact Domino in your country” for local technical support:

<http://www.domino-printing.com>

## LASER SAFETY NOTICE

<p><b>DANGER:</b></p>	<p><b>LASER RADIATION. Class 4 LASER PRODUCT. Risk of personal injury.</b></p>
	<p><b>Depending on the local installation environment, additional class 1 laser safety guarding may be necessary before the coder can be operated or made ready for use.</b></p> <p>This is necessary to safeguard against accidental exposure to direct or scattered radiation.</p> <p>Guidance on creating and fitting laser guarding can be found in part 1 of the Product Manual.</p> <p><b>Avoid eye or skin exposure to direct or scattered radiation.</b></p> <p>Set up a laser safety zone and wear appropriate eye protection if laser radiation above class 1 may become available. Information about the correct type of Protective Safety Goggles can be found within the Product Manual.</p> <p>Contact with direct or scattered laser radiation can cause permanent damage to the eyes, including instant blindness. Laser radiation can also burn human tissue and start fires.</p> <p>This product emits class 4 laser radiation from the laser aperture on the scan head. This radiation is a pulsed, invisible, infrared laser radiation with a wavelength of 900 – 1200 nm, a maximum pulse energy of 2 mJ and CW Power of &lt;175 W.</p> <p>Before the product is used, make sure that fumes, particles and gases that are created during the coding process are safely removed. This can be achieved by installing an extraction system that is adapted to the planned coding process.</p>

<b>DANGER:</b>	<b>LASER RADIATION. Class 4 LASER PRODUCT. Risk of personal injury.</b>
	<p>Do not use controls or adjustments of performance or procedures, other than those specified in this manual.</p> <p>Do not apply changes or modifications that are not expressly approved by the manufacturer.</p> <p>To do so may result in hazardous radiation exposure and may void the user's authority to operate the equipment.</p>

<b>DANGER:</b>	<b>LASER RADIATION. Class 4 LASER PRODUCT. Risk of personal injury.</b>
	<p><b>Avoid eye or skin exposure to direct or scattered radiation.</b></p> <p>Do not open the laser source.</p> <p>The laser source (box inside the product) contains an embedded laser device that emits invisible radiation in the region of 900 - 1200 nm with a total output power of up to 175 W. This radiation is not accessible under normal use or service conditions. Opening of the protective housing of the laser source box is only allowed for special, according to the laser source manufacturer plans, trained technicians.</p>

<b>WARNING:</b>	<b>Class 3R Laser Radiation. Risk of personal injury.</b>
	<p><b>Avoid direct eye exposure.</b></p> <p>This product emits a class 1 aiming beam as standard for F221i and F520i and class 3R for F720i and optionally provides class 3R laser radiation for aiming purpose from its laser aperture on the scan head.</p> <p>This radiation is a visible red laser radiation with a wavelength off 630 - 670 nm and CW Power of &lt;1.4 mW.</p> <p>This radiation can be dangerous to the eye if it is viewed directly. Avoid a direct exposure of the eye. It is not harmful to the human skin.</p>

<b>DANGER:</b>	<b>LASER RADIATION. Class 4 LASER PRODUCT. Risk of personal injury.</b>
	<p><b>Avoid direct eye exposure o direct or scattered radiation.</b></p> <p>If the yellow beam delivery cable is damaged or overstressed it may emit class 4 laser radiation while the laser source is energised! Avoid to bend it to a diameter below &lt;150 mm, to twist it more than 180 degrees or to stress it with repeated movement.</p> <p>The beam delivery cable is not class 1 under a worst case single fault, no cable break or fibre break detection is offered on this product. The integrator must either include the beam delivery cable inside the class 1 enclosure with the pulsed laser aperture or undertake suitable measures to ensure that under reasonable and foreseeable use the cable is suitably positioned to prevent it from becoming damaged or mishandled.</p>

THIS PAGE INTENTIONALLY LEFT BLANK

# CONTENTS

	Page
PREFACE .....	3
Laser Safety Notice .....	5
HEALTH AND SAFETY .....	11
General .....	11
Electrical Voltage .....	12
Laser Radiation .....	12
Aiming Beam .....	13
Harmful Dust and Vapours .....	13
Touching the Lens .....	13
Scan Head Mirrors .....	13
Protecting the Lens .....	13
Noise .....	14
Crushing .....	14
Laser Coding Process .....	14
Velocity Kit Option .....	14
INSTALLATION .....	15
Water Cooling .....	15
Lifting and Moving the Controller .....	16
Beam Delivery Cable (Fibre) .....	19
Interlock Switches .....	19
Emergency Off .....	19
OPERATION .....	21
F-Series Laser Marking System .....	21
Controls and Indicators .....	22
TouchPanel and Interface .....	22
Controls .....	22
Indicators LEDs Fibre Laser .....	25
Interlock Indicator 1 and 2 .....	25
Shutter Preparation / Error Indicator .....	25
Shutter State / Error Indicator .....	26
Laser Indicator / Error Indicator .....	26
LED Start-up Display on Power Up for Systems with Shutter .....	26
Switching On and Off .....	27
Switching On the Controller .....	27
Switching On the Laser Head .....	27
Switching Off the Laser Head .....	27
Switching Off the Controller .....	27

## Preface

F-Series Connectivity .....	28
Webserver .....	29
Quickstep Interface .....	30
Home Screen .....	30
General Functions .....	32
Initial Setup .....	33
Display Settings .....	33
Setting the Master Clock .....	33
Security Management .....	33
Creating and Editing a Message .....	34
Add Text .....	34
Add a New Barcode .....	35
Add an Image .....	35
Add a New Variable .....	36
Add a New Clock .....	36
Add a New Counter .....	37
Add a New Prompted Field .....	39
Add a New Link .....	40
Undo / Redo .....	40
Message .....	41
Edit .....	42
Add .....	42
Move .....	43
Zoom .....	43
Re-order Visual Items .....	43
Item Selection List .....	44
Resize .....	44
Message Store and File Management .....	45
Selecting an Existing Message .....	45
File Manager .....	45
MAINTENANCE .....	47
Checking Fans and Air Vents .....	47
Controller .....	47
General Cleaning .....	50
Service: Replacement of Components .....	51
Applications without Shutter .....	51
Applications with Shutter .....	51
Shutter Safety Relay .....	51
FAULT FINDING .....	53
System Status Messages .....	53

# HEALTH AND SAFETY

## GENERAL

The F-Series laser coding systems are designed and built in accordance with international standards and other technical specifications, which are to be observed. The equipment conforms to current technology and approved safety requirements.

This safety standard, however, can only be achieved if all intended and required measures have been taken and are constantly observed. It is part of the operator's duties to plan these measures and check their continuing implementation.

Domino F-Series laser coding systems are produced by Domino Laser GmbH Germany. For special details contact your local support office. The F-Series laser coding systems have been developed and designed for fully automated coding of packaging materials and products by use of laser radiation.

The user must ensure that

- Depending on the local installation environment, additional class 1 laser safety guarding may be necessary before the laser coding system can be operated or made ready for use. The laser emits class 4 laser radiation from the laser aperture on the scan head.
- The equipment is only to be used for its intended purpose.
- The equipment is only operated in a good, serviceable condition, and that all safety installations are regularly checked for their serviceability.
- Personal protective safety goggles for maintenance and repair personnel are required and made available.
- Only suitable and approved tools and equipment are used.
- This User Guide is complete and in a legible condition at the equipment location at all times.
- The valid rules and laws regarding accident prevention are available and observed.
- Only according to Domino definitions sufficiently qualified and authorised personnel shall operate, maintain, and repair the laser coding system. These personnel are regularly instructed in all matters concerning appropriate labour safety and environmental protection, and that they are familiar with the operating manual, particularly the safety instructions contained herein.
- Any safety and warning labels on the laser coding system must not be removed and must remain in a readable condition.

## SPECIFIC DANGERS

### Electrical Voltage

In the F-Series laser coding system, the maximum operating voltage is the connected mains voltage, which can pose a hazard to health. The mains voltage to be maintained is shown on the type label.

Work on live components must only be performed by authorised personnel.

In the case of a defective power supply, operation of the laser coding system is to be stopped immediately and is only to be repaired by authorised personnel.

Keep the controller closed at all times. Only expressly authorised personnel are permitted to open the controller.

### Laser Radiation

Laser radiation can pose a risk to eyes and skin. The danger is not only posed by direct laser radiation, but also by scattered radiation and reflections from the work piece or the machine into which the laser is integrated. The degree of injury depends on the duration of the effect, the power and the wavelength of the laser.

Lasers and their installations are classified into seven laser protection classes, depending on their potential danger. Class 1 is the safest and class 4 is potentially the most harmful. These classes are defined in detail in EN60825: 2014 Part 1 and are summarised below:

- |          |   |
|----------|---|
| Class 1  | Laser products that are safe during use, including long-term direct intrabeam viewing, even when exposure occurs while using telescopic optics. Class 1 also includes high power lasers that are fully enclosed so that no potentially hazardous radiation is accessible during use (embedded laser product). Intrabeam viewing of class 1 laser products which emit visible radiant energy may still produce dazzling visual effects, particularly in low ambient light. |
| Class 3R | Laser products that emit radiation that can exceed the MPE under direct intrabeam viewing, but the risk of injury in most cases is relatively low. Dazzle, flash-blindness and afterimages may be caused by a beam from a class 3R laser product in the visible wavelength range, particularly under low ambient light conditions. This may have indirect general safety implications resulting from temporary disturbance of vision or from startle reactions.           |
| Class 4  | Laser products for which intrabeam viewing and skin exposure is hazardous and for which the viewing of diffuse reflections may be hazardous. These lasers also often represent a fire hazard.   |

## **Aiming Beam**

The system contains an internal aiming beam with a wavelength of 630nm to 670nm.

This laser is a class 1 laser for F221i and F520i and class 3R for F720i.

## **Harmful Dust and Vapours**

When radiating materials by means of a laser, harmful dust and vapours can be produced.

The user is responsible for appropriate measures, e.g. an exhaust system, to reduce such harmful dust and vapours to a level that complies with the allowed maximum concentration of pollutants at the work place.

## **Touching the Lens**

Fused silica lenses are used in the F-Series laser system.

Lenses must not be touched.

If the lens has been soiled, it must be thoroughly cleaned before any operation.

## **Scan Head Mirrors**

Never touch the mirrors of the scan head.

The mirrors are inside the scan head and there is a small risk of touching them when cleaning the lens.

When the mirrors have been touched accidentally thoroughly clean the mirrors.

## **Protecting the Lens**

The scan head has a fused silica lenses that is accessible from the outside if the protection cap is removed.

This lens is protected by an aluminium frame, but the silica lens insert is fragile and can break and splinter if pressure is applied on it. Edges of the broken lens and loose splinters can lead to cut injuries or contamination.

Protect the lens with the protection cap while the system is installed, transported or not used for an extended time but always ensure the cap is removed before you use the laser.

If a lens is broken replace it immediately and make sure to safely remove all splinters to avoid cross contamination into other areas where silica particles may become a health hazard. Avoid touching the broken lens parts with the fingers. Use sticky tape to carefully collect all silica splinters and parts. Include the broken lens and the sticky tape in a strong plastic bag and dispose in the normal waste container.

## Noise

All systems emit during operation a noise level lower than 80dB(A). No personal protective equipment against noise is needed. Local regulations may differ.

## Crushing

There is a crushing hazard during installation and operation due to:

- Product moving along the laser head
- Products moving into and out of protective housing
- Doors and maintenance openings of protective housings

Especially prevent the risk of crushing.

## Laser Coding Process

Potential fire risks could result from examples as listed below. This list is not considered to be complete. Local conditions must be considered as well.

- Coding on not specified material (e.g. easily inflammable or explosive materials)
- Invalid parameter settings (e.g. very low coding speed)
- Invalid parameter settings due to corrupted code data
- Coding constantly on the same product (e.g. no product movement caused by various reasons)
- Inflammable gases or materials inside the working area

In coding mode the laser beam is controlled by software which must be considered as part of the risk assessment.

*Note: Install a fire detector near the laser to monitor the coding process.*

## Velocity Kit Option

The fibre laser can be configured with an optional Velocity Kit for higher coding speed and therefore higher productivity. Once the laser is switched on there will always be a laser power output of below 5 mW. This enables an even faster start-up of the laser and thus high speed.

*Note: This option requires hardware adoptions to be enabled in the software.*

# INSTALLATION

## WATER COOLING

A factory fitted option is available to cool the laser head and controller with factory water or water from a water chiller. Use only clean and oil free water.

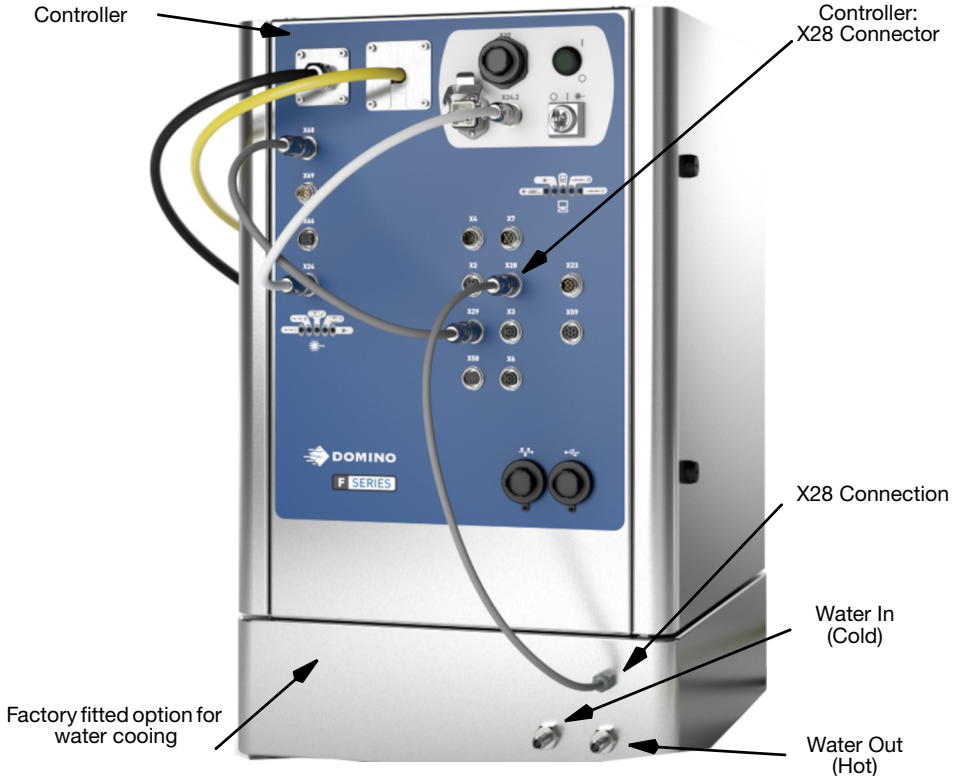



Hoses with an inner diameter from 3/8 inch (9.5 mm) to 10 mm may be used. Hoses have to be fastened with hose clamps.

Maximum allowed water pressure is 5 bar. At a pressure higher than 5 bar, a pressure reducer must be installed on the inlet of the cooler and limited to 4 bar. The water flow is regulated automatically by a magnetic valve. The water flow, in the worst case (Coding Duty Cycle 97%, ambient temperature 45°, water temperature 27°) is 2 litres per minute. The water out of the controller has to be connected to one of the connectors of the laser cooling plate to cool the laser. The water out of the laser cooling plate is the final water out of the laser coding system.

An optional water chiller (part number L015148) is available from Domino.

## LIFTING AND MOVING THE CONTROLLER

<b>WARNING:</b>	<b>Heavy Equipment. Risk of injury.</b>
 	<b>Two man lift required.</b> The controller weighs over 40kg.

An optional mobility kit (Domino part number EPT031573) with 4 castors is available to assist moving the controller.



For lifting, four hooks are supplied with the laser system which may be mounted to the four top corners of the controller (as shown below).

4 hooks mounted to the top side of the controller



## LASER PROTECTION WINDOW

Domino recommends installing a protection window in front of the laser lens, to keep the lens clean. A protection window can be ordered from Domino - part number EPT031339. This protection window has to be checked and cleaned regularly (recommended daily) depending on the production rate. These intervals may be expanded afterwards.

<b>WARNING:</b>	<b>Sensitive material.</b>
 	<b>Exchange the windows if they can no longer be cleaned.</b>

### **GUARDING LABELS**

The laser coding system is fitted with international laser warning signs and numbers of laser performance data based on standard IEC 60825-1:2014 “Safety of laser products” during manufacturing.

To ensure that the meaning of the laser warning symbols is understood, the laser safety standard defines supplementary text on these signs to increase comprehension.

Signs with the supplementary text in English language are attached during manufacturing.

It is mandatory to apply extra signs in the local language as defined in local standards (i.e. the Machinery Directive for European countries) if the local language differs from English. Check their presence and readability regularly.

Warning signs and their locations on the laser coding system are explained in the Product Manual. Refer to the topics “Mandatory Warning Labels for Installation” and “Local Language Labels for Installation”.

### **GUARDING**

Guarding is an integral part of the laser safety.

Laser guarding must be constructed and certified by specialists that are trained and have understood the use of the local laser regulations. The international standards mentioned here are a good starting point but may not fulfil all local regulations.

This Domino laser coding system can emit class 4 laser radiation through the lens of the scan head when the dual channel safety circuit is closed and the system is powered.

Before powering the system, ensure that the environment is securely guarded against accidental exposure to direct or scattered radiation. You must also verify that the yellow beam delivery cable is in good condition and either included in the secure laser guarding, or other suitable measures ensure that under reasonable and foreseeable use the cable is protected from becoming damaged or mishandled.

Inside the laser guarding, provide suitable measures against the risk that the laser energy may act as an ignition source.

Domino recommends the following standards for assessing and constructing guarding:

- ISO 12100:2010 “Safety of machinery - General principles for design - Risk assessment and risk reduction“.
- IEC 60825-1 Safety of laser products - Part 1: “Equipment classification and requirements and certify the guarding to be a laser class 1 guarding”.
- More detailed laser guarding information is available in the standard IEC 60825-4 Safety of laser products - Part 4: “Laser guards”.
- As your guard will be part of a machinery setup, the standard ISO 14120 Safety of machinery – Guards – “General requirements for the design and construction of fixed and movable guards” must be taken into account.

For additional support in planning and verifying laser guards, contact Domino.

### **Beam Delivery Cable (Fibre)**

The beam delivery cable is not class 1 under a worst case single fault, no cable break or fibre break detection is offered on this product. The integrator must either include the beam delivery cable inside the class 1 enclosure with the pulsed laser aperture, or undertake suitable measures to ensure that under reasonable and foreseeable use, the cable is suitably positioned to prevent it from becoming damaged or mishandled. The beam delivery cable has not been designed for robotic applications. The Laser must not be designed into systems where the Beam Delivery Cable will be subject to high levels of acceleration and twist, or combination thereof. If this is a requirement for the integration, please contact Domino to discuss the application in more detail.

The minimum bend radius for the fibre is 75 mm.

### **Interlock Switches**

Interlock switches must be fitted to all access guards preventing access to the laser output lens and coding area that can be opened without the use of access tools.

Interlock switches must be wired into the laser control circuit so that the laser beam is disabled when the guard is removed.

### **Emergency Off**

Integrate the laser into the emergency off circuit of the machine into which the laser is integrated. Install an emergency off push button near the laser coding systems which turns off the laser. Connect the emergency off push button via the interlock circuit to the controller.

THIS PAGE INTENTIONALLY LEFT BLANK

# OPERATION

## F-SERIES LASER MARKING SYSTEM

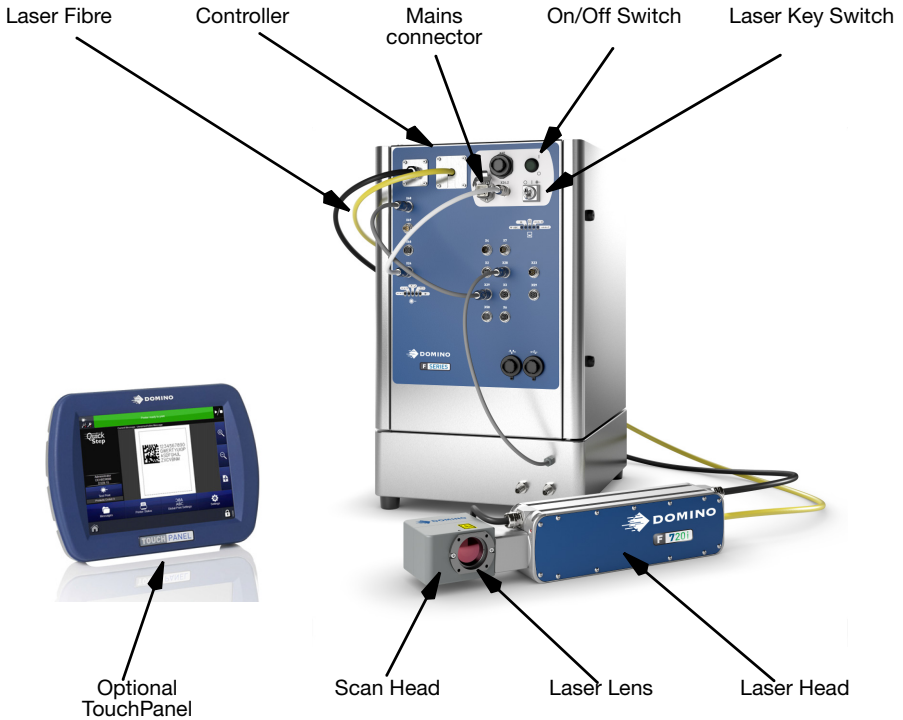

## CONTROLS AND INDICATORS

The User Interface, Indicator Lamps and Software icon functions are described in the following paragraphs:

### TouchPanel and Interface

The software is operated via a PC keyboard, TouchPanel or Web Browser. The optional TouchPanel if connected, allows entry by touching the tabs and function keys on the screen. An onscreen keyboard is included in the software.

*Note: The Web Browser does not support the message editor.*

### Controls

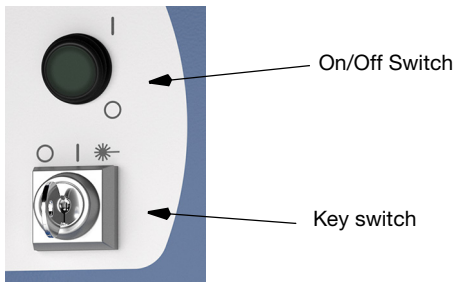

ON / OFF BUTTON - Starts and stops the controller

KEY SWITCH - Starts and stops the Laser (fans and laser tube)

The key switch has three positions:

- “0” Laser off
- “1” Laser ready
- “\*” Laser start

## Indicator LEDs Controller

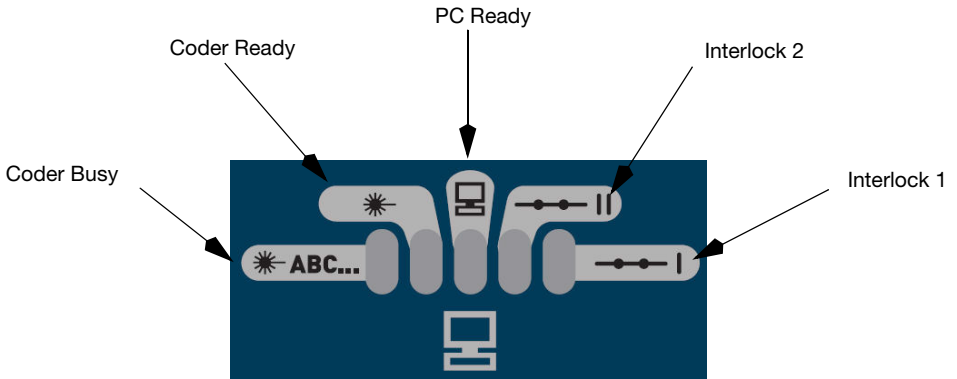

- Interlock 1 - Illuminates when the interlock 1 is closed
- Interlock 2 - Illuminates when the interlock 2 is closed
- PC Ready - Illuminates when the controller is ready for the laser to be started.
- Coder Ready - Illuminates when the laser is powered up and coding system is ready to code
- Coder Busy- Illuminates when the laser is coding

The activation of the laser power supply is also indicated by two red (Power) LEDs on the front and one at the rear of the laser.

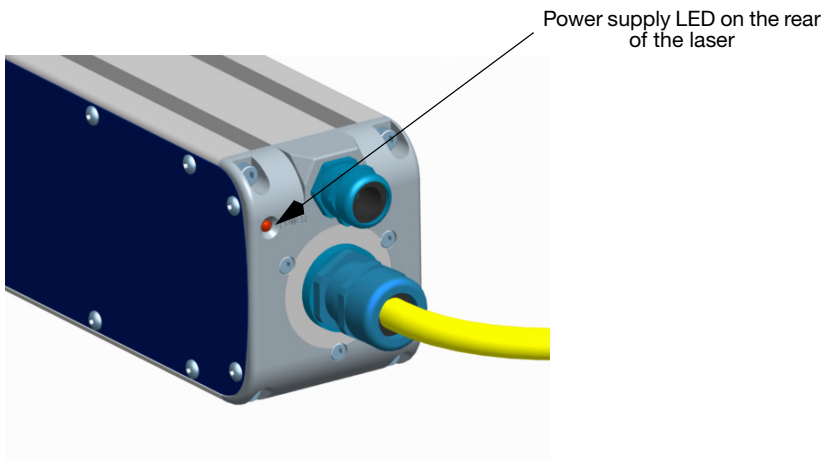

## Operation

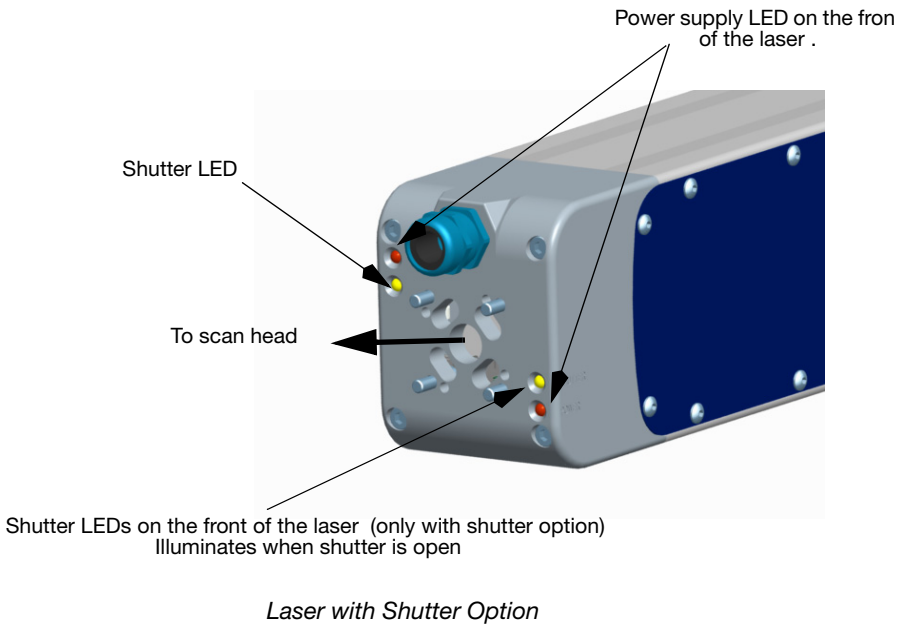
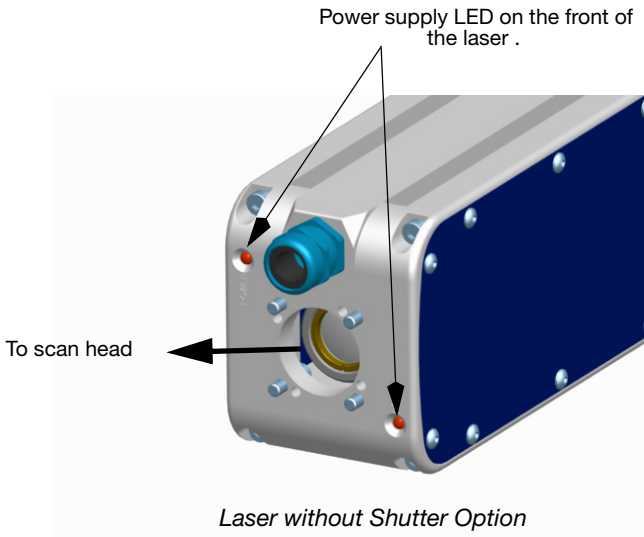

## Operation

### Indicators LEDs Fibre Laser

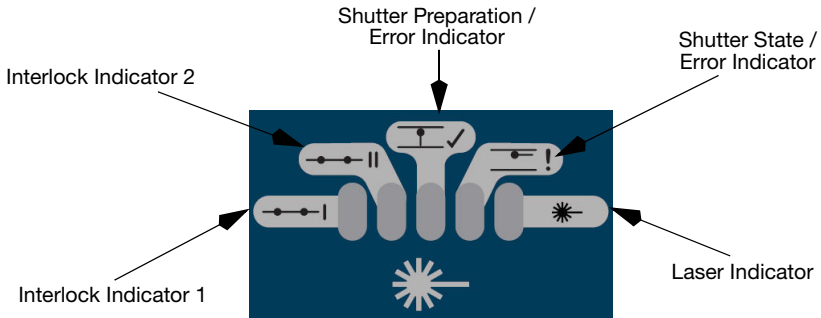

### Interlock Indicator 1 and 2

Both interlock 1 LED and interlock 2 LED are GREEN	Interlock 1 and 2 respectively are closed.
LEDs are alternately flashing in RED colour	Wrong order was in the interlock loops e.g. open and close one loop only. Correct and restart the process. The interlock has been opened while the shutter self-test was running.
Both interlock 1 LED and interlock 2 LED parallel RED flashing	An electrical error (cross connection) was detected. Check wiring and restart the process.
Both Interlock 1 LED and interlock 2 LED are lit RED	The safety relay is completely shut down. Power cycling is required.

*Note: Within approximately 8 seconds after power up (boot phases of the safety relay) the display of both interlock LEDs is not valid.*

### Shutter Preparation / Error Indicator

Flashing GREEN	Waiting for start command.
Lit GREEN	Ready.
Lit RED	A shutter malfunction is present.
Flashing RED	A shutter malfunction was detected but is no more present.
Flashing ORANGE	A shutter malfunction was detected - waiting for start command.
Lit ORANGE	No shutter and shutter controlling is equipped.

## Shutter State / Error Indicator

Lit YELLOW	Shutter is open, caution laser radiation is possible!
Lit RED	Shutter temperature display (after power-up only).
Lit RED (permanent)	Shutter feedback cross-check failed.
Flashing RED while the GREEN Shutter preparation LED is lit or flashing	Shutter is close to over temperature.
Flashing RED while GREEN shutter preparation LED is flashing	A shutter over temperature, or sensor fail (<10°C) occurred. Therefore the laser was switched off. Restart is possible.
Flashing RED while GREEN shutter preparation LED is off	A shutter temperature sensor fail (<10°C) is present. Therefore the laser is switched off.
Flashing RED while GREEN shutter preparation LED is off	A shutter over temperature is present. Therefore the laser is switched off.

*Note: The GREEN shutter preparation LED flashing is suppressed if one or both interlock is not closed.*

## Laser Indicator / Error Indicator

Lit YELLOW	Laser source ready for emission.
Lit RED (error)	Laser is not (correctly) started.

## LED Start-up Display on Power Up for Systems with Shutter

After power up, the laser unit will start an error test display in the following sequence:

- Shutter state error; each sec. means 10° Celsius of scan head temperature. This display shows that the temperature sensor of the shutter housing is properly connected, and that the LED works.

Then, approximately 8 seconds after power up:

The 4 LEDs from top to bottom:

- Extinguish for a moment
- Light up (RED) for 1 second each, top to bottom
- Extinguish for a moment
- Display status as described above

If unauthorised changes are performed, the warranty will be invalidated.

## SWITCHING ON AND OFF

<b>WARNING:</b>	<b>Class 4 Laser. Risk of personal injury.</b>
	<p><b>Only use the laser coding system for its intended purpose.</b></p> <p><b>Only trained personnel may operate the laser coding system.</b></p> <p><b>Only operate the system with all required cables connected and all parts mounted.</b></p> <p><b>Do not disconnect any cables during operation.</b></p>

<b>CAUTION:</b>	<i>Risk of material damage.</i>
	<p>Remove the lens cap before use.</p> <p>It is used to prevent damage or external soiling that will cause a reduction in laser performance.</p>

### Switching On the Controller

At the controller switch the On/Off button from 0 to 1. Wait until the PC READY  indicator has illuminated.

### Switching On the Laser Head

Turn the key switch from position “0” to position “1”. To start the laser turn the key clockwise to the laser symbol and hold it for at least 1 second. The key automatically turns back to position “1”.

- The laser needs a warm-up phase of 3 seconds.

The CODER READY  indicator illuminates. After initialising the software and starting the laser, the coding system is ready.

Laser power is also displayed by a red LED on the rear of the laser head.

### Switching Off the Laser Head

- Turn the key switch from position “1” to position “0”. The laser hardware is switched off.

### Switching Off the Controller

- At the controller switch the On/Off button from 1 to 0. The controller will immediately switch off.

## F-SERIES CONNECTIVITY

The F-Series is operated either via a remote TouchPanel or via a PC running on Microsoft Windows 10® with installed QuickStep software.

To connect to one F-Series, the TouchPanel is connected to the X59 TouchPanel connector of the controller.

The TouchPanel then displays the UI relating to that coder.

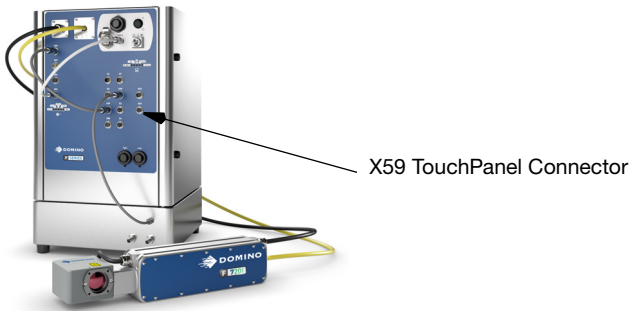

One TouchPanel can control multiple F-Series in the same network if required.

Details about the coder being controlled are displayed in the Home screen which lists: the logged in user, the coder's name and the coder model. To connect to another coder in the network, follow the steps below:

- (1) Disconnect from the current coder by pressing the Lock button and selecting Disconnect From coder to display the coders' list screen
- (2) Press the Lock button and select Unlock UI Settings, enter the password (QS)
- (3) Press Settings, select Broadcast (default) as the connection method
- (4) Go back to the coders' list screen and press Refresh to view a list of all coders in the network
- (5) Select the required coder

A list of favourite remote coders can be created, as follows:

- (1) From the coder's list screen, press the Lock button and select Unlock UI Settings, enter the password (QS)
- (2) Press Settings and select Favourite as the connection method.
- (3) Press Add Favourite and fill in the required fields manually or get a favourite coder from broadcast
- (4) Select a coder from the Broadcast list
- (5) Press Add to Favourites

## **Websver**

One may also connect to the coder's UI via standard web browser. The following web browsers are supported:

- Microsoft Internet Explorer from version 9.0 on
- Mozilla Firefox from version 22 on
- Google Chrome from version 27 on
- Apple Safari from version 6 on

Not the complete functionality of the UI is available when connecting to the coders via a web browser.

Not available is:

The Message Editor which is accessed via *Home Screen > Settings > Message Editor* or via *Home Screen > Messages > New Message / Edit coding Message*

To connect, enter "http://[IP address of the controller]" in the address field of the web browser.

## QUICKSTEP INTERFACE

### Home Screen

When powering up the coder and after login, the following Home screen is displayed.

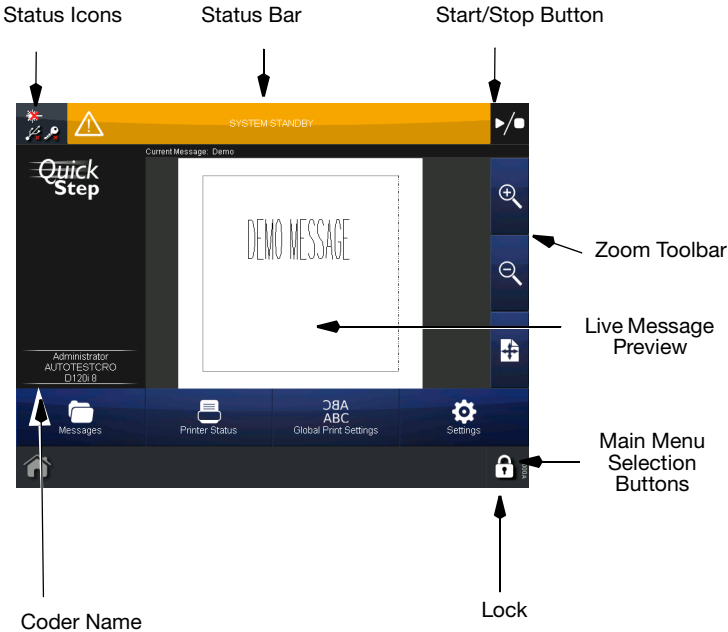

<p>Status Icons:</p>	<p>Displays current status of coder, e.g:</p> <ul style="list-style-type: none"> <li>Laser active (Laser is busy - laser emission!)</li> <li>USB device connected (USB device connected to controller or TouchPanel)</li> <li>Dongle connected (Pharma or Service dongle connected)</li> </ul>
----------------------	--

## Operation

Status Bar:	Displays coder and alert status. If more than one alert is present, the highest priority alert is displayed.
Start/Stop Button:	Enables coding <i>If the laser is switched off, it must be switched on before coding can take place.</i> Stops coding Restarts the coder
Zoom Toolbar:	Zooms in and out and the working area
Live Message Preview:	Preview and main working area. Used for settings and message creation.
Main Menu Selection Buttons:	Navigate to the four main QuickStep areas where all functions of the operational software can be accessed.
Lock Button:	Locks the screen to prevent accidental changes Login and logout Disconnects from coder
Coder Name:	Shows the coder which is being currently controlled

## STATUS BAR

The status bar displays informal, warning and error messages - background colour of the status bar:

- Green - the condition is normal, no action is required
- Amber - the condition is warning and may prevent coding, however if coding was enabled and the reason for this fault has become obsolete it automatically re-enables coding
- Red - the condition prevents coding and requires immediate correction

*Note: Click on the status bar to acknowledge alerts.*

## General Functions

The following illustration shows the Global Coding Settings screen and the various screen areas.

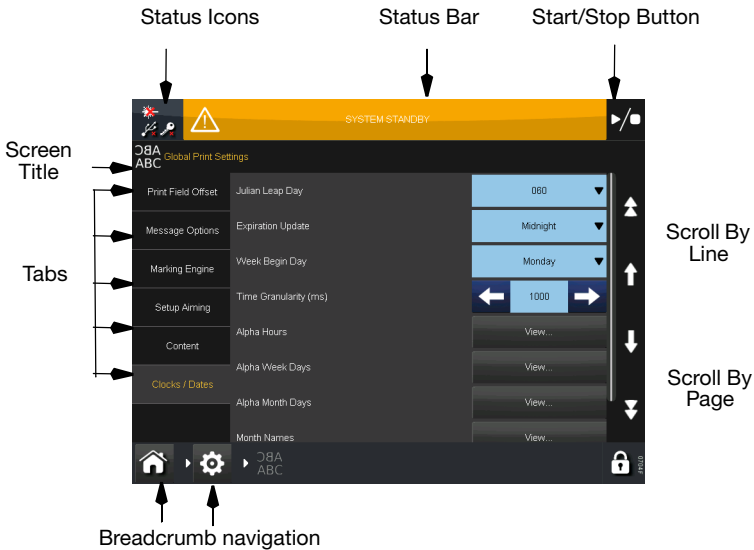

Click long on a button to get a description. Click long on a button of the *Settings* area to move this button to the *Home* screen.

*Note:* The breadcrumb navigation shows the current location inside the menu structure. One can switch the user interface level by clicking on the icons; it is also a quick way to return to the home screen from any page.

## Initial Setup

The initial setup configures the overall look of the interface and also configures basic settings and presets for coder operation.

### Display Settings

*Home > Settings > Regional > Language and Keyboard*

Set:

- Language
- Keyboard layout
- IME Scheme (Input Method Editor / Keyboard Layout)
- Primary currency

### Setting the Master Clock

*Home > Settings > Regional > Date and Time*

Set:

- System date
- System time (24 hour clock)
- Time zone
- Automatic Daylight Saving Time
- Setup the Network Time Protocol

## Security Management

Password protection prevents unauthorised changes to the software, and unauthorised operation of the laser coding system.

Some functions can only be accessed from higher user levels; the higher the user level, the more functions are available. The current user level is displayed in Quickstep home screen.

The functions that can be accessed for each user level are as follows:

User Level	Functions	Password
Logout	View the main functions	none
Operator	Start / stop coding, acknowledge alerts	op
Supervisor	Create/Edit messages; Change Coding Parameters; Access to Editor and Save Editor	sv
Administrator	Edit most of the setup	Not published

Extended system parameter settings can only be changed after entering the Administrator password. This password is only known by employees authorised by Domino.

*Note: If unauthorised changes are performed, the warranty will be invalidated.*

Changing the passwords after the initial installation is recommended.





## Creating and Editing a Message

### Add Text

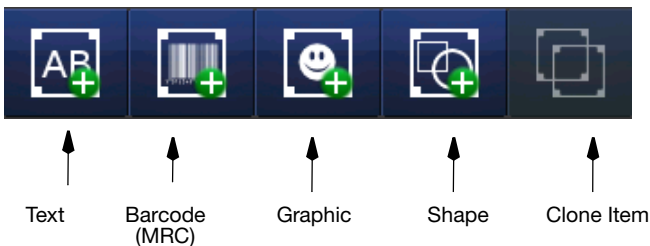
- (1) Select *Messages > New Message* or *Settings > Message Editor* to open the Message Editor.
- (2) Press on the screen within a specific area of the Message Editor where you require the item to appear. A cross hair will appear at this location.
- (3) Select the Add  icon.



The *Add* sub-menu displays.



- (4) From the sub-menu select the Text  icon. Change keyboards by selecting the appropriate Alternative Keyboard icon at the bottom of the text entry screen.
- (5) Enter the required text using the keyboard and select the green tick icon when finished.
- (6) To change text, select the text item and then the Keyboard icon on the *Edit* sub-menu.
- (7) To change text parameters (Object Name, Position, Bold, Width etc.), use the sub-menu (Font, Alignment) or select More...
- (8) To delete an object, select the object and select the delete  icon of the *Edit* menu.
- (9) Activate the message for coding by sending it to the coder  via the *File* menu .

## Add a New Barcode

To add a barcode to the message:



- (1) Press on the screen within a specific area of the Message Editor where you require the item to appear. A cross hair will appear at this location.
- (2) Select the Add Barcode  icon and select the type and specification required from the list and editable text boxes.
- (3) Use the Text, Variable, Edit Variable and Properties tabs to enter the barcode data.
- (4) Select the green tick icon to insert the code into the message.
- (5) Edit the barcode by highlighting the barcode within the message and using the sub-menu or by selecting More...
- (6) Activate the message for coding by sending it to the coder  via the *File* menu .

## Add an Image

To insert an image into the message:

- (1) Press on the screen within a specific area of the Message Editor where you require the item to appear. A cross hair will appear at this location.
- (2) Select the Image  icon from the Add menu.
- (3) An images folder stored in the coder will open.
- (4) Browse for the required image.
- (5) Select the green tick icon to insert the image.

Monochrome Bitmap (\*.bmp), DXF (\*.dxf) (up to Version 12, information about 3-dimensional objects is discarded, fonts and labels are not supported) and Hewlett Packard Graphics Language HPGL (\*.plt) black white graphic file formats are supported. Supported commands for HPGL import are: Arc Absolute, Arc Relative, Plot Absolute, Plot Relative, Pen Up, Pen Down

- (6) Select the Move  icon to move the copied item to the desired location within the message.
- (7) Activate the message for coding by sending it to the coder  via the *File* menu .

Use the File Manager (*Home > Settings > File Manager*) to copy an image from a USB device to the controller.

## Add a New Variable

Message or system variables may be added. Message variables may only be used in the message in which they have been created. System variables can be used in all messages.

- Message variables are created via *Home > Settings > Message Editor >*

*Add*  *> Text*  *> Add Variable* .

- System variables are created via *Home > Settings > Message Editor >*

*File*  *> Add/Edit Variable*  *> Add Variable* .

*Note: System variables are referenced within message via a link. Insert a link into a message to use a system variable.*

The following variables can be created and added to the message:



- Clock (message & system)
- Counter (message & system)
- Prompted Field (message only)
- Link (message only)
- Script (message only)
- Coding (message only)
- Shift Code (message only)
- Text Insert (message & system)
- Text Variable (message & system)
- Text Link (message only)

*Notes: (1) System variables are emptied on a power cycle.*



*(2) All steps below are described for local variables as they are the same for system variables.*

## Add a New Clock

To add a new offset clock to the message:



- (1) Press on the screen within a specific area of the Message Editor where you require the item to appear. A cross hair will appear at this location.
- (2) Select the Add  icon.
- (3) From the sub-menu select the Add Text  icon.
- (4) Select *+Variable > +Create New > Clock*.
- (5) The scope cannot be changed - use the *File* menu to create a global clock.
- (6) Enter a name for the clock or use the default name and use the new screen to select the format.
- (7) Select the required offset parameters (Days, Months, Years and/or Hours, Minutes, Seconds and/or Weeks) and add values using the keyboard. Select the green tick icon when each parameter is completed.

## Operation



- (8) Review the entered information and select the green tick icon if correct or press in the required field to add or change values.
- (9) Select the green tick icon to enter the offset clock into the message.
- (10) Activate the message for coding by sending it to the coder  via the *File* menu .

### Add a New Counter

To add a new counter to the message:

- (1) Press on the screen within a specific area of the Message Editor where you require the item to appear. A cross hair will appear at this location.
- (2) Select the Add  icon.
- (3) From the sub-menu select the Add Text  icon.
- (4) Select *+Variable > +Create New > Counter*.
- (5) The scope cannot be changed - use the *File* menu to create a global counter.
- (6) Enter a name for the counter and enter the Format String “N” for numerical and “A” for alpha characters.
- (7) Select a Leading Character Mode from the drop down options: None, Blank or Custom. If a custom character is selected in the Leading Character box, enter the character required.
- (8) In the Step Control box, select the option required to activate the increment:  
Coding Start  
User Input (Rising Edge)- specify the User Input to be used  
User Input (Falling Edge)- specify the User Input to be used.
- (9) In the External Reset box, select  
None,  
Coding Enable,  
Application Start  
Message Load  
User input Rising Edge  
User input Falling Edge.
- (10) In the Counter Repeat box, enter the number of items to be coded before the counter increments (default value is ‘1’).
- (11) Step Size sets the increment value of the selected counter from 1 to 99999. The default value is ‘1’.
- (12) Set the current value in the selected alphanumeric format of the counter.
- (13) Set the start value in the selected alphanumeric format for the counter. If the start value is larger than the end value the counter will count backwards.



## Operation

- (14) Set the end value in the selected alphanumeric format of the counter.
- (15) Edit, if required, the Alpha Field String. to be used for the alpha designators in the counters. All alphanumeric characters are available for use in this string. The maximum string length is 26 characters. The default string is A to Z (including all characters).
- (16) Select an Ending Action: Select  
None  
Disable, User Output  
User output and disable  
Select the User Output if activated.
- (17) If required, set a Batch Link to another counter when this counter has it's end value and select the linked counter from the drop down list.
- (18) Review the entered information and select the green tick icon if correct or press in the required field to add or change values.
- (19) Select the green tick icon to enter the counter into the message.
- (20) Activate the message for coding by sending it to the coder  via the *File* menu .

## Add a New Prompted Field

Prompted text fields may be inserted into messages. The content of these text fields is entered in QuickStep after sending the message to the coder. The content format has to be specified when creating these text fields in a message in the *Message Editor*.

To add a new prompted field to the message:

- (1) Press on the screen within a specific area of the Message Editor where you require the item to appear. A cross hair will appear at this location.
- (2) Select the **Add**  icon.
- (3) From the sub-menu select the **Add Text**  icon.
- (4) Select **+Variable > +Create New > Prompted Field**.
- (5) Enter a name or use the default name for the prompted field object.
- (6) Set a default value in the format matching the input mask for the prompted field.
- (7) Enter a prompt which is displayed on screen when the data for the prompted field should be entered. (After sending the message to the coder).
- (8) Select an input mask for the prompted field which specifies the type of content for the prompted field. Possible formats:



Mask	Description
0	Mandatory numeric character 0-9
9	Optional numeric character 0-9
L	Mandatory alpha character A-Z or a-z
?	Optional alpha character A-Z or a-z
A	Mandatory alphanumeric character 0-9, A-Z or a-z
a	Optional alphanumeric character 0-9, A-Z or a-z
C	Mandatory any character
c	Optional any character
#	Optional currency symbol €, \$, £ or ¥
&	Mandatory any character or space

- (9) Review the entered information and select the green tick icon if correct or press in the required field to add or change values.
- (10) Select the green tick icon to enter the prompted field into the message.
- (11) Activate the message for coding by sending it to the coder  via the *File* menu



## Add a New Link

To add a new link to the message:

- (1) Press on the screen within a specific area of the Message Editor where you require the item to appear. A cross hair will appear at this location.
- (2) Select the **Add**  icon.
- (3) From the sub-menu select the **Add Text**  icon.
- (4) Select **+Variable > +Create New > Link**.
- (5) Enter a name or use the default name for the link object.
- (6) Specify the source of the link, e.g. a counter or a clock or message content element. System variables are entered into a message via a link.
- (7) Select the green tick icon to enter the link into the message. The link object will have the same content as the source object.
- (8) Activate the message for coding by sending it to the coder  via the **File** menu



## Undo / Redo



Undo or redo the last editing steps in the message editor including change of settings or parameter settings.

*Note: Creating a new message clears the undo cache - no undo to the last message is possible.*

## Message

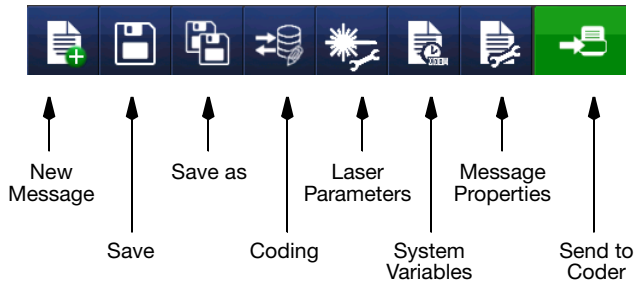

- **New Message**  
Creates a new message.
- **Save**  
Saves the current message in a selected message store.
- **Save as**  
Saves the current message with a given name in a selected message store.
- **Coding**  
Selects a source for the coding variable.
- **Laser Parameters**  
Create, delete and edit laser parameter sets.
- **System Variables**  
Create global variables.
- **Message Properties**  
Message settings overwrites system settings of Fields, Coding on the Fly, Vector Sorting and activate usable fields. Also enables the user to activate Optical Correction, Tube Distortion and PN Transformation.
- **Send to Coder**  
Sends the current message to the coder and activates it for coding.

## Edit

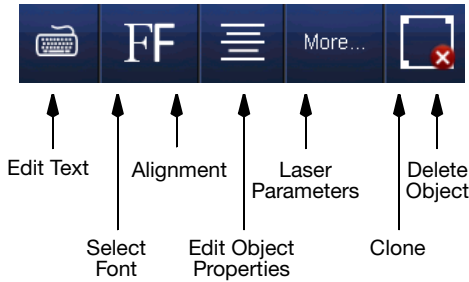

*Edit menu for a text object.*

- Edit Text  
Opens the keyboard to edit the text content
- Select Font  
Opens the list of available fonts to select a font
- Alignment  
Sets the alignment of the object
- Edit Object Properties  
Allows editing the properties of the object
- Laser Parameters  
Set laser parameters for the object
- Cone Item  
Duplicates the object
- Delete Object  
Deletes the selected object

## Add

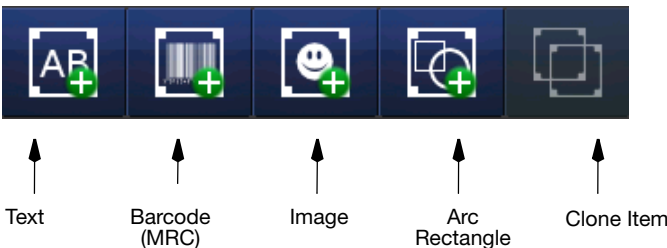

## Move



Select an object in the editor by clicking on it and move it in the desired direction by clicking on the arrow icons.

Drag and drop can also be used. Select and hold the item within the message and move it to the desired location.

## Zoom

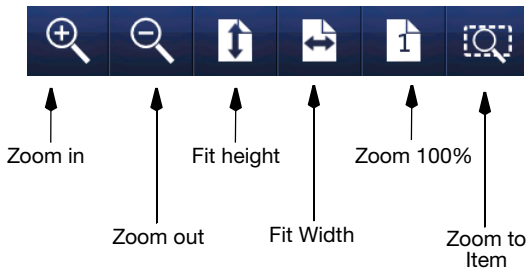

To view the item(s) in the Message field, or the whole Message field in a different size, select the item(s) and then select the appropriate button from the above toolbar:

- Incrementally zoom in on the message area
- Incrementally zoom out of the message area
- Fit whole message height to area
- Fit whole message width to area
- Zoom to 100% (actual size) of Message
- Zoom selected item to fit into message area

## Re-order Visual Items



Sets the order of objects to code.

Select an object of the list and use the arrows to change the order.

## Item Selection List



Selects multiple or all objects of a message. Select the items of the list to be selected. Or click on “Select all” to select all objects. Click on “Clear Selection” to have no object selected.

## Resize

Resize an object by selecting it and dragging the red mark of the object.

## MESSAGE STORE AND FILE MANAGEMENT

### Selecting an Existing Message

*Note: Where no message is selected for coding, no live message will be displayed in the Home screen.*

- (1) Select the Messages button to open the Message Store.
- (2) Select the required message from the list.
- (3) Choose to Edit, Preview or Send to Coder.

*Note: Send to Coder will revert to the Home screen. The selected message will then be displayed.*

### File Manager

*Home > Settings > File Manager*

File Manager is a useful way of reviewing and organising stored messages, images and scripts.



Using File Manager it is easy to rename files, create new folders and copy content between folders.

New Store:	Create a new store for messages, images and scripts. <i>Note: A new message store can only be created in the messages folder.</i>
Edit:	Rename Copy Cut Delete Details
Paste:	Used with the Copy/Cut commands to add files into folders.

THIS PAGE INTENTIONALLY LEFT BLANK

## MAINTENANCE

### CHECKING FANS AND AIR VENTS

<b>WARNING:</b>	<b>Mains electricity. Risk of death.</b>
 	<b>Switch off and un-plug before undertaking any work on the laser coding system.</b>

The fans are located at the bottom of the controller.



A fan defect immediately poses a danger of overheating that may result in damage to the BCP7 controller, therefore the fans must be checked once a month.

#### Controller

- (1) Check the fans for bearing noises. If bearing noise exist, the respective fan must be replaced.
- (2) Check the fan filters of the controller (2 on the left side and 2 on the right side) for blockages and dirt. If necessary, exchange them. This may be easily done from the outside without opening the controller.

## CLEANING THE LENS

<b>CAUTION:</b>	<i>Risk of Material Damage</i>
	<p>Do not use compressed air from the installation for cleaning.</p> <p>Do not use water for cleaning. The lenses are not water resistant.</p> <p>Clean carefully. There is a risk of scratch marks on the lens which will reduce the coding quality.</p>

<b>WARNING:</b>	<b>Mains electricity. Risk of death.</b>
 	<p><b>Switch off and unplug from the mains before undertaking any work on the laser coding system.</b></p> <p>Ensure the mains power plug is removed before cleaning the lens.</p>

The lens must be checked monthly for dust, and if necessary be cleaned with (absolutely clean) compressed air from a can.

For all other dirt, the lens must be cleaned with 99,9% Isopropyl Alcohol and the Domino lens cleaning kit. The kit consists of two parts (both are needed):

- EPT033842 - SP Lens Cleaning Cotton Balls (Set of 50)
- EPT033843 - SP Lens Cleaning Cotton Swabs (Set of 100)



Cleaning procedure as follows:

- (1) Take an unused cotton ball and soak it in Isopropyl Alcohol.
- (2) Lightly wipe with ONE PASS ONLY across the surface of the lens.
- (3) Inspect the cotton ball. If dirt or oil is present, repeat steps (1) to (2).
- (4) Take an unused cotton swab and soak one end in Isopropyl Alcohol.
- (5) Lightly wipe across the border area of the surface of the lens.
- (6) Inspect the cotton swab. If dirt or oil is present, repeat steps (4) to (5).
- (7) Use an unused cotton swab to lightly wipe excess liquid from the lens.

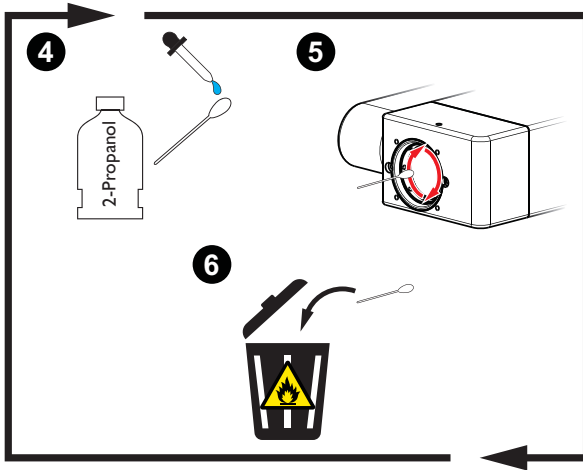
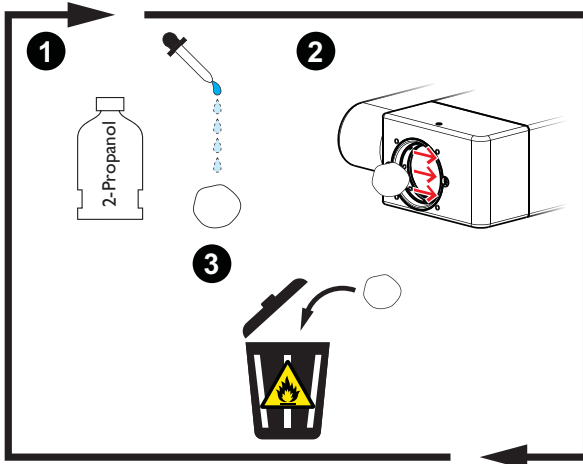
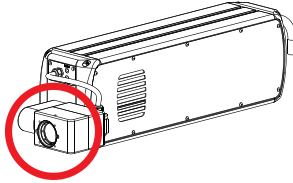
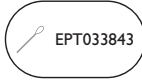
# Maintenance



## GENERAL CLEANING

<b>WARNING:</b>	<b>Mains electricity. Risk of death.</b>
 	<b>Switch off and un-plug the mains supply to the laser coding system and the connected installation.</b>

The outer surfaces may be cleaned with a damp cloth and a mild cleaning agent only. No humidity must get into the system.

**SERVICE: REPLACEMENT OF COMPONENTS****Applications without Shutter**

Maximum cycles of Safety Relay PNOZ S4 (opening of guard door when laser is coding)	15 Million
Maximum cycles of Safety Relay PNOZ S4 (opening of guard door when laser is not coding)	100 Million

**Applications with Shutter**

Maximum cycles of Shutter	10 Million
---------------------------	------------

**Shutter Safety Relay**

Maximum cycles of Safety Relay	10 Million
--------------------------------	------------

THIS PAGE INTENTIONALLY LEFT BLANK

## FAULT FINDING

### SYSTEM STATUS MESSAGES

	<b>Status Message</b>	<b>Cause</b>	<b>Suggested Action</b>
11	Product left coding area (moving too fast?)	The message has not been completed in time.	Slow down the conveyor, reduce the coding time, or move the text upstream on the field.
12	Product left coding area (moving too fast?)	The message has not been completed in time.	Reduce the coding time or move the text upstream on the field.
13	List buffer repeat count fail.	Internal Fault.	Restart the system. Contact Domino.
14	Maximum code to code distance exceeded.	The maximum distance between coding trigger signals has been exceeded and an expected coding trigger was not received.	Restart the system. Contact Domino.
15	Coding trigger signal ignored.	A coding trigger has been received too soon after the previous.	Restart the system. Contact Domino.
16	Maximum laser on time exceed (laser disabled by hardware).	The laser has been firing for longer than expected.	Restart the system. Contact Domino.
17	Laser warm up.	A short warm up period is required before use.	Restart the system. Contact Domino.
30	Scan head power missing.	There is no +/-15 V at the scan head, or no data returning from scan head.	Restart the system. Contact Domino.
31	Scan head temperature out of valid range.	The scan head is cold.	Restart the system. Contact Domino.

## Fault Finding

	<b>Status Message</b>	<b>Cause</b>	<b>Suggested Action</b>
32	Scan head warming up - please wait.	The scan head is cold.	Wait for the heaters in the scan head motors to warm the scan head, the coder can be used but you may experience very minor position errors.
33	Controller over temperature.	The temperature in the controller is very cold or too hot.	Check that the fans are working and that the filters are not blocked.
51	Controller near over temperature.	The controller is getting quite hot.	Check that the fans are working and that the filters are not blocked.
56	coder ready to code.	coder will code if a coding trigger signal arrives.	Information Only.
58	No Message loaded	There is no valid message loaded into the controller.	Load a message and send it to coder.
549	Turn keyswitch to enable coding	The safety relay needs to be set after an interlock has been opened.	Turn keyswitch to start position, or give a remote start input (the "Play" button on the UI will not function).
550	System disabled	The keyswitch is at position 0.	Turn the keyswitch to position 1.
551	Aiming turned on	The aiming beam, configurable in the global settings, is turned on.	Information Only.
552	External Interlocks Open	The interlock or interlocks are open.	Close the guards to 'make' the interlocks.
553	External Interlock 1 Open	The interlock switch 1 is open	Close the guards to 'make' the interlocks.
554	External Interlock 2 Open	The interlock switch 2 is open	Close the guards to 'make' the interlocks.
555	Air Fault	Not enough air flow to cool the laser.	Check the air regulator filters and pressure settings.

## Fault Finding

	<b>Status Message</b>	<b>Cause</b>	<b>Suggested Action</b>
556	Vacuum Fault	The DPX is not running.	Make sure the DPX is serviceable and running.
557	Filter not ok	The DPX filters are blocked.	Change the DPX filters.
578	System Standby	The keyswitch is at position 1 but not yet set by turning the keyswitch or remote start.	Turn the keyswitch to start position, or give a remote start input, or press the “Start” button on the user interface.
579	coder enabling.	The laser is switched on but warming up.	Wait for the coder to be ready.
580	Inconsistent Laser On State	The laser start input level is being overridden by a user interface laser on selection or by a fault message.	Restart the system. Contact Domino.
581	Next controller not ready	The next controller in a “chain” in a Multihead configuration is not ready.	Restart the system. Contact Domino.
582	Controller Idle (Multi Head System)	The system is part of a multi head “chain” but has been disabled (see install options). This is for information only.	Restart the system. Contact Domino.
583	External Interlock has been opened	One or both interlocks was opened but is now closed.	Restart the system. Contact Domino.
594	Safety Relay Fault	There was a laser start command present while one or both (CAT3/4) interlocks where not closed.	Make sure the interlocks are closed before giving the laser start input.

*Note: For all other errors or messages contact Domino.*

## Fault Finding

THIS PAGE INTENTIONALLY LEFT BLANK



## Domino F-Series User Guide

Domino Printing Sciences plc has a policy of continuous product improvement, the Company therefore reserves the right to modify the specification contained within this document without notice.

© Domino Printing Sciences plc 2024. All rights reserved.



For additional documentation, including other available languages, either scan the QR code, or go to <https://mydomino.domino-printing.com>

**Domino UK Limited**

Trafalgar Way  
Bar Hill  
Cambridge CB23 8TU  
United Kingdom

Tel: +44 (0)1954 782551  
Fax: +44 (0)1954 782874  
Email: [enquiries@domino-uk.com](mailto:enquiries@domino-uk.com)

**Domino Amjet Inc.**

1290 Lakeside Drive  
Gurnee IL.60031  
U.S.A.

Tel: +1 847 244 2501  
Fax: +1 847 244 1421  
Email: [solutions@domino-na.com](mailto:solutions@domino-na.com)



EPT066750\_5 English