

Extrusion Ink Coding Station

EICS250 Print Stand

Domino's **EICS250 Print Stand** is suitable for space-constrained production lines. This versatile print stand is designed for extrusion and rewinding applications, including products such as pipes, tubes, and cables, with a **diameter of 20mm to 250mm**. In order to support an easy line integration at different places, this solution offers the possibility of moving from one extrusion line to another due to its mobility. It can be equipped with a state-of-the-art **head mounting unit** and an **encoder unit** to provide a comprehensive Extrusion Coding Solution.

The **EICS Print Stand** is suitable for a variety of production settings beyond traditional extrusion applications and can be equipped with a variety of different technologies.

Benefits

- ◆ Waste reduction and minimise down time due to protected printhead and encoder allowing knots and lumps to pass without additional production slowdown or operator intervention
- ◆ Flexible, expandable and compatible with Domino's EICS Control Rack Lite
- ◆ Covers various installation needs
- ◆ Easy installation on production lines where space is limited
- ◆ Flexible arrangement for printing on top of products, and with material flow from left or from right
- ◆ No printhead adjustment needed when changing product diameters and material, as the encoder unit ensures that the printing position is top of product aligned

Facts & Features

- ◆ Product diameter between 20mm to 250mm
- ◆ Line speeds up to 500m/min (dependent on product diameter)
- ◆ Height adjustment for different production requirements
- ◆ Bar width (2 units – 310mm / 3 units – 460mm) suitable for confined spaces
- ◆ Head mounting unit (i-Pulse RS & i-Pulse standard) to reject lumps and knots
- ◆ Inline wash station to ensure fast printhead cleaning and a hassle-free precise repositioning of the printhead
- ◆ Optional spring-loaded encoder unit for product speed measurement
- ◆ Jacking castors for mobility



www.domino-printing.com

Technical specification

Extrusion Ink Coding Station – EICS250 Print Stand

Print Stand	
Dimension	W x D x H: 420mm x 790mm x 1540mm
Weight	47kg
Product height levels	800–1300mm
Mobility	Jacking castors
Ground clearance	153mm
Direction of production	Left to right & right to left
Head mounting unit	
Printhead	i-Pulse RS or i-Pulse
Inline wash station	Ensures fast printhead cleaning and precise repositioning
Line speed	Up to 500m/min (depending on product diameter)
Fine adjustment	+/- 15mm two axis
Weight	6.5kg
Encoder unit	
Equipment	Ax-Series standard encoder
Line speed	Up to 500m/min
Product diameters	From 20mm to 250mm
Weight	2.8kg
Optional features	
CIJ system	For EICS Print Stand extension
Ax-Series	Ax150i, Ax350i, Ax550i

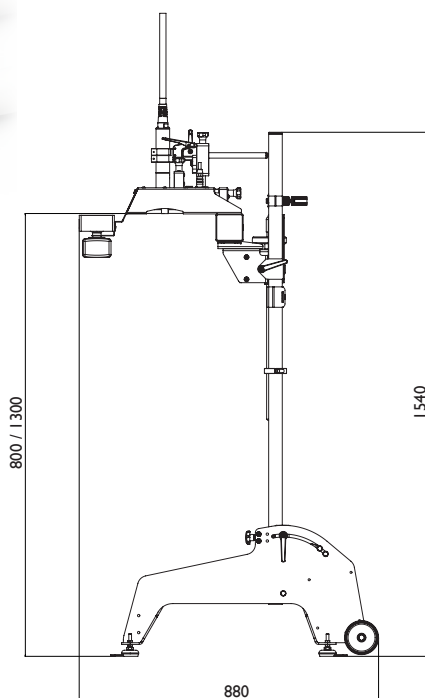
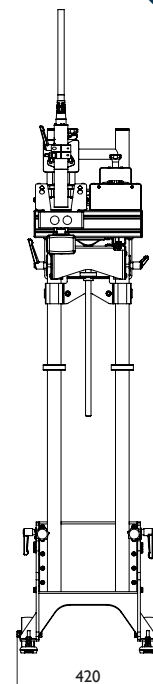

TALK TO AN EXPERT

Email: enquiries@domino-uk.com
 Website: www.domino-printing.com
 Phone: +44 (0)1945 782551