

TLS, designed to beat downtime

Domino Twin Labelling Station

Recover the investment in months, enjoy the benefits for years

The Ultimate Print & Apply Solution with two modes of operation. 'Auto-Swap' mode can increase OEE by up to 5% by reducing line stoppage. 'Alternate' mode can increase throughput to over 200 products per minute.

Intelligent design, combining twin printers and system controller in a compact footprint for flexible and simple integration.



Innovation based on proven technology

In 'Auto-Swap' mode, the system automatically and seamlessly switches from one printer to the other without stopping the line, minimizing downtime due to planned and unplanned stoppages like consumable changes, maintenance, and breakdowns.

It's powered by two Domino **Mx350i** printers known for fast and flexible printing and it comes with a range of applicators designed to apply labels on different types of products, cases and boxes.



Compact & Flexible

- ◆ Flexibility to switch between contact (tamp) and non-contact (blow) applications
- ◆ Left and Right Hand Printer for ease of use
- ◆ Small footprint for convenient installation and easy integration in demanding layouts
- ◆ Adjustable height from 600mm to 1500mm
- ◆ Direct thermal or transfer available
- ◆ Can accommodate all standard industry label sizes for the application
- ◆ 316 Stainless steel option available



Faster & Safer

- ◆ High-speed tamp applicator with built-in blow function can label up to 100 products per minute
- ◆ Printers slide out position of labelling to allow convenient and safe consumable changes and maintenance
- ◆ Designed for safety, innovative pinch point protection
- ◆ Faster and more efficient maintenance thanks to accessible preventative maintenance points



To succeed in the long run you need a winning team

Compliance Assurance

With legislative requirements constantly evolving, Domino **TLS** offers flexibility to adapt to changing regulations. It ensures that your labeling practices remain compliant, reducing the risk of non-compliance penalties and production halts.

Efficiency Optimization

The **TLS** Controller optimizes labeling processes, improving Overall Equipment Effectiveness (OEE) by managing the switching between printers when there is low level media (labels or ribbon) or printer breakdown.



Easy operation

Intuitive HMI based on Domino's industry leading GUI software. Makes operating the system easy and user friendly.

Vision System & rejection

Check every product's label and manage sub-optimal labels with our vision and rejection system using either Domino **R-Series** or Omron cameras. This is particularly important for Track & Trace operations.

Range of reject options for any product size or weight for fast & accurate removal of product.

	Mx350i-T4*	Mx350i-T6*	TLS Bracket	
Print Width	Up to 108 mm	Up to 162 mm	Printers	1x LH and 1x RH Mx350i T4 or T6
Print Technology	Thermal Transfer/ Direct Thermal		Height Options	
Resolution	12 dots/mm (300dpi)		Low	600-900 mm
Label & Ribbon Lengths	Up to 600m		Medium	900-1200 mm
Recommended Label width	25-110 mm	25-150 mm	High	1200-1500 mm
Recommended Label length	15**-210 mm	15**-210 mm	Weight	Approx. 210 Kg max. without printers
TLS Speed	Up to 200 ppm in "alternate" mode		Options	
Control System			Camera Bracket Reject Device and Chute Reject Bin	
Communication	4x Ethernet, TCP/IP, 2x USB-A, 1x USB-B			
I/Os Configurable	12 Inputs and 12 Outputs			

* Mx350i-T specific brochure available
 ** 55 mm if Label Check required

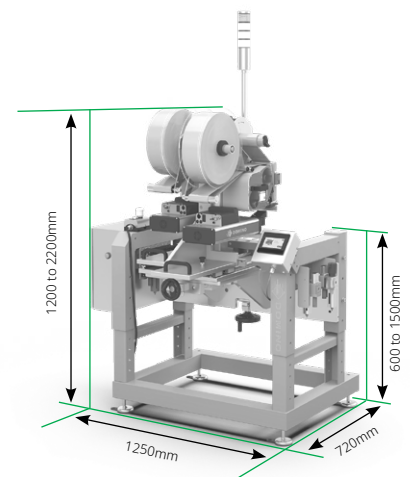

TALK TO AN EXPERT

Tobacco@Domino-uk.com