

# Ax350i – cutting edge printing technology

Our goal is to provide you with the best fit for the coding requirements in your production. The **Ax350i** ink jet printer delivers high quality codes in almost any environment on virtually any surface and product.

The **Ax350i** is compatible with Industry 4.0 standards. Connecting to **Domino Cloud** enables remote diagnostics and 24/7 visibility of your printers' performance. The touchscreen user interface provides a class-leading user experience.

Domino's service-free ink system with **i-Pulse** printhead technology utilizing Domino-developed inks provides clear, readable text, graphics and barcodes while ensuring regulatory compliance.



## Maximum uptime on production lines

- ◆ A flexible modular design, sealed IP66 electronics enclosure, dynamic on-board monitoring and control enable easy line integration and excellent prints even in harsh environments.
- ◆ The **Ax350i** is service-free; only the **iTechx** module (ITM) needs to be replaced once annually, which is a less-than-ten-minutes operator task.
- ◆ Coding automation and integration into your ERP and MES business systems are supported. Connect to **Domino Cloud** to benefit from remote printer performance overviews and diagnostics.



## i-Pulse printhead technology

- ◆ Printheads start up first time even after extended shutdowns thanks to Domino's unique nozzle-sealing technology.
- ◆ Best readability and reliability at faster speed in a higher 9-drop resolution (versus traditional 7 drops) plus up to 24% less ink usage result from optimized ink drop formation.
- ◆ Printheads for every application: 90-degree angled and rotatable printheads for narrow products and highly durable, hygienic round steel variants for heavy duty environments.

## Consistent quality codes

- ◆ Domino supplies a range of inks manufactured to GMP (Good Manufacturing Practice) which are compliant with leading global legislation for food packaging.
- ◆ Our inks offer lasting adhesion, lightfastness and high contrast even on difficult substrates (e.g. polyolefins) and after harsh post-print processes.
- ◆ Environmental-friendly options, reduced ink consumption, optimized packaging and fully-depleting cartridges reduce waste and ecological footprint.

[www.domino-printing.com](http://www.domino-printing.com)



# A complete solution



Our services are designed to provide operational insight so you can eliminate downtime and maximize production efficiency

## Operational support

An outstanding level of care, wherever you are. Our **SafeGuard** packages provide high-quality, on-site assistance and AR-enabled remote guidance from our engineers. **SafeGuard** helps to ensure we can be with you when you need us most.

## Automatic code inspection

Ensure every code that leaves your factory is present and correct, and free up operator time. With the **R-Series**, Domino's range of vision control systems, you can automate your code inspection to validate code presence, placement, and readability.

## Control software

Minimize errors using **Domino Automation** software. Control your product codes from a central location and streamline product changeovers. **Domino Automation** uses standard communication protocols and can be integrated into existing ERP systems.

## Smart production

Gain operational insight by connecting your printer to **Domino Cloud**. Obtain production analytics dashboards and receive system error alerts. **Domino Cloud** provides you with the information you need to run your operations more efficiently.

## Technical specification Ax350i

Printing Specification	
Printhead nozzles	60µm 75µm
Speed – 1 line, 5 dot characters(m/s)*	7.1 6.8
Dot size(mm)**	0.31 0.4
Print heights (single print head)	Up to 32 dots/20mm
Print heights (Duo)	Up to 64 dots/40mm
Supported code formats	full unicode support text, graphics, 1-D, 2-D codes
Ownership Specification	
User interface	7" and 10.4" touch screen options
Conduit length	3m & 6m options
Printhead type	Straight, H90, V90 and RS
Software	<b>QuickStep 3</b>
Comms ports	Cabinet USB port (x1); Ethernet RJ45 port (x1) EtherNet/IP (Optional)
Printer status monitoring	4 stage beacon output (x1); 3 stage alarm output (x1)
Cartridge replacement (Ink and make-up)	Auto recognition;
Service interval***	20 second operator task; no line stop required
Material	Sub 10 minute operator task, line stop required
	Typically every 12 months
	304 steel, IP55 cabinet; IP66 electronics enclosure
Consumables****	
Inks	Wide range of black and colored inks including options for food packaging, eggshells, color change, industrial, UV-fluorescent
Ink cartridge volume	825ml
Make-up cartridge volume	1200ml
Optional Hardware Packs*****	
Extended comms pack	Cabinet USB port (x1); control port (x1); touchscreen / Ethernet port (x1)
RS232 pack	RS232 port (x1)
GPIO pack	I/O – 4 inputs/4 outputs (x1)
Extended I/O pack	I/O - 12 inputs / 6 outputs (x1)
Optional Performance Packs	
Operator assistance pack	Label templates; barcode scanning for labels and data entry; local security manager
Green pack	Up to 20% reduction in make-up emissions; configurable printhead and ink-system stand down for reduced power usage
Continuous printing pack	Dedicated user screens for faster changes during production; easier label creation; high speed print formats (ST & HS rasters)
Advanced security pack	Full security manager to secure user interface and provide customizable permissions based on individual user logins

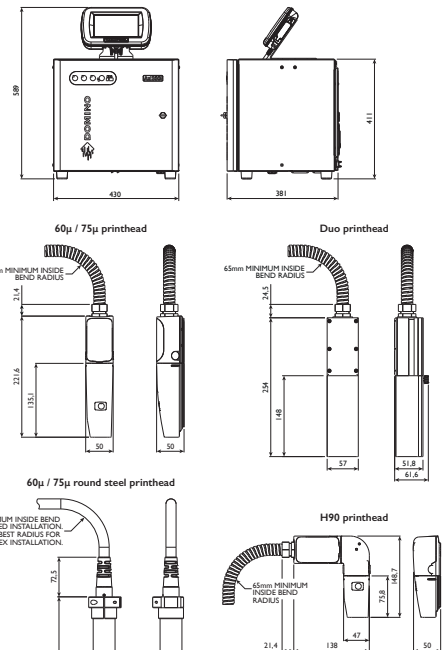

\*Speed quoted at the following characters per inch ---- 60µm = 10 characters. \*\*Dots size may vary depending on substrate type. \*\*\*Service interval is ink type dependent. \*\*\*\*This product has a Quality Management System that means that it will only work with Domino circuitry, and it uses dynamic security measures to block non-Domino circuitry from being used. From time to time updates to the circuitry will be issued by Domino to maintain the effectiveness of the Quality Management System. \*\*\*\*\*May vary per sales region.

## Logos and 2D Codes



## Multi Language and Mixed Fonts



## TALK TO AN EXPERT

800.444.4512

solutions@domino-na.com

www.domino-na.com/contact