

Ax550i – advanced heavy duty printer

The **Ax550i** heavy-duty continuous ink jet (CIJ) printer is designed to deliver high quality codes even in the harshest environments onto virtually any surface and product.

The **Ax550i** is compatible with Industry 4.0 standards. Connecting to **Domino Cloud** enables remote diagnostics and 24/7 visibility of your printers' performance. The touchscreen user interface provides a class-leading user experience.

Domino's service-free ink system with **i-Pulse** printhead technology utilizing Domino-developed inks provides clear, readable text, graphics and barcodes while ensuring regulatory compliance.



Maximized production uptime

- ◆ The stackable marine grade 316 stainless steel cabinet is dust-tight and with a sealed IP66 electronics enclosure made to withstand washdowns, high-pressure water blasting, or chemicals.
- ◆ The **Ax550i** is service-free; only the **iTechx** module (ITM) needs to be replaced once annually, which is a less-than-ten-minutes operator task.
- ◆ Coding automation and integration into your ERP and MES business systems are supported. Connect to **Domino Cloud** to benefit from remote printer performance overviews and diagnostics.



i-Pulse printhead technology

- ◆ Printheads start up first time even after extended shutdowns thanks to Domino's unique nozzle-sealing technology.
- ◆ Best readability and reliability at faster speed in a higher 9-drop resolution (versus traditional 7 drops) plus up to 24% less ink usage result from optimized ink drop formation.
- ◆ Printheads for every application: 90-degree angled and rotatable printheads for narrow products; highly durable, hygienic round steel variants for heavy duty environments; 40 μ and 50 μ printheads for small, precise codes and the Duo printhead for doubled speed.

Codes to create a lasting impression

- ◆ Domino supplies a range of inks manufactured to GMP (Good Manufacturing Practice) which are compliant with leading global legislation for food packaging.
- ◆ Our inks offer lasting adhesion, lightfastness and high contrast even on difficult substrates (e.g. polyolefins) and after harsh post-print processes.
- ◆ Environmental-friendly options, reduced ink consumption, optimized packaging and fully-depleting cartridges reduce waste and ecological footprint.

www.domino-printing.com



A complete solution



Our services are designed to provide operational insight so you can eliminate downtime and maximize production efficiency

Operational support

An outstanding level of care, wherever you are. Our **SafeGuard** packages provide high-quality, on-site assistance and AR-enabled remote guidance from our engineers. **SafeGuard** helps to ensure we can be with you when you need us most.

Automatic code inspection

Ensure every code that leaves your factory is present and correct, and free up operator time. With the **R-Series**, Domino's range of vision control systems, you can automate your code inspection to validate code presence, placement, and readability.

Control software

Minimize errors using **Domino Automation** software. Control your product codes from a central location and streamline product changeovers. **Domino Automation** uses standard communication protocols and can be integrated into existing ERP systems.

Smart production

Gain operational insight by connecting your printer to **Domino Cloud**. Obtain production analytics dashboards and receive system error alerts. **Domino Cloud** provides you with the information you need to run your operations more efficiently.

Technical specification Ax550i

Printing Specification	
Printhead nozzles	40µm 50µm 60µm 75µm
Speed – 1 line, 5 dot characters(m/s)*	5.3 5.9 7.1 6.8
Dot size (mm)**	0.23 0.26 0.31 0.4
Print heights (single print head) Print heights (Duo) Supported code formats	Up to 32 dots/20mm Up to 64 dots/40mm full unicode support text, graphics, 1-D, 2-D codes
Ownership Specification	
User interface Conduit length Printhead type Software Comms ports Printer status monitoring Cartridge replacement (Ink and make-up) Servicing – ITM replacement Service interval*** Material	7" and 10.4" touch screen options 3m & 6m options Straight, H90, V90, RS and Duo QuickStep 3 Cabinet USB port (x1); Ethernet RJ45 port (x1) EtherNet/IP (Optional) 4 stage beacon output (x1); 3 stage alarm output (x1) Auto recognition; 20 second operator task; no line stop required Sub 10 minute operator task; line stop required Typically every 12 months 316 stainless steel, IP55 cabinet; IP66 electronics enclosure
Consumables****	
Inks Ink cartridge volume Make-up cartridge volume	Wide range of black and color inks including options for food packaging, eggshells, color change, industrial, UV-fluorescent 825ml 1200ml
Optional Hardware Packs*****	
Extended comms pack RS232 pack GPIO pack Extended I/O pack	Cabinet USB port (x1); control port (x1); touchscreen / Ethernet port (x1) RS232 port (x1) I/O – 4 inputs/4 outputs (x1) I/O - 12 inputs / 6 outputs (x1)
Optional Performance Packs	
Operator assistance pack Green pack Continuous printing pack Advanced security pack	Label templates; barcode scanning for labels and data entry; local security manager Up to 20% reduction in make-up emissions; configurable printhead and ink-system stand down for reduced power usage Dedicated user screens for faster changes during production; easier label creation; high speed print formats (ST&HS rasters) Full security manager to secure user interface and provide customizable permissions based on individual user logins

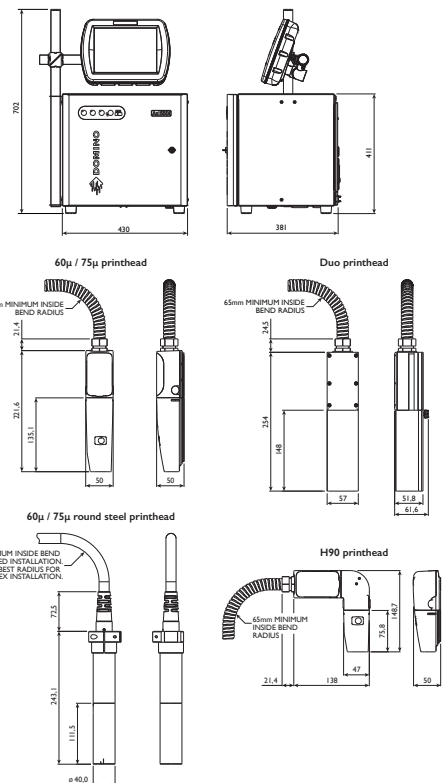

*Speed quoted at the following characters per inch --- 60µm = 10 characters. **Dots size may vary depending on substrate type. ***Service interval is ink type dependent. ****This product has a Quality Management System that means that it will only work with Domino circuitry, and it uses dynamic security measures to block non-Domino circuitry from being used. From time to time updates to the circuitry will be issued by Domino to maintain the effectiveness of the Quality Management System. *****May vary per sales region.

Logos and 2D Codes



Multi Language and Mixed Fonts



TALK TO AN EXPERT

800.444.4512

solutions@domino-na.com

www.domino-na.com/contact