



F-Series

Premium Fiber Laser

Built for coding. Made for you.



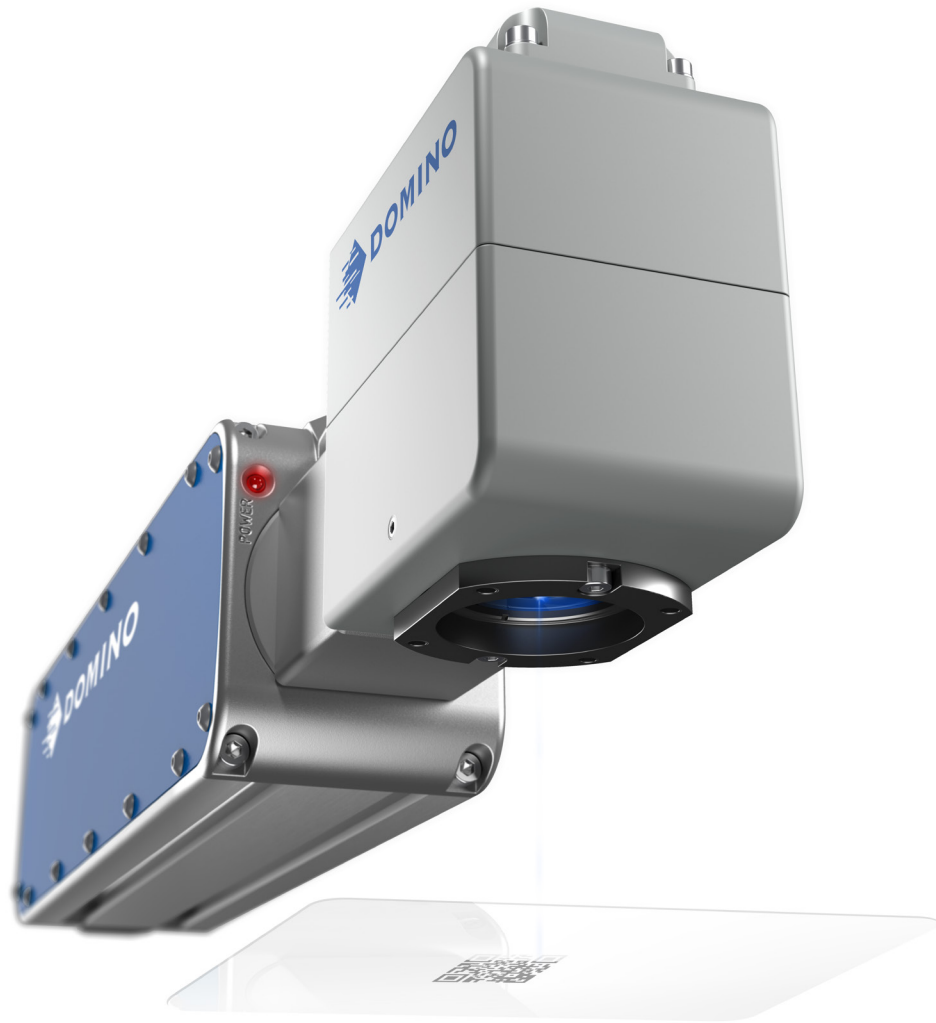

Domino's **F-Series** range

High-quality codes for less

F-Series is the ultimate fiber laser for your production line, allowing you to reduce your total cost of ownership for coding and marking while achieving top code quality. This fiber laser is a Domino developed, market-proven laser technology, which is versatile and optimized for a variety of industries. With the **F-Series** range, Domino offers the models **F230i**, **F520i** and **F720i**, so you can choose the optimal power class and wavelength for your coding needs.

Total Cost of Ownership

A more cost-effective coding technology

When considering a Domino laser for your production chain you can rely on the cost-effectiveness of the **F-Series**. The combination of extended lifetime, high production uptime, and low consumables consumption ensures a much lower total cost of ownership than other coding technologies.

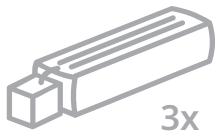

Up to 3x longer lifetime

In the challenging environments of industrial production, some coding technologies can have a relatively short life of less than 6 years before needing replacement. Due to limited moving parts and precision engineering, Domino's **F-Series** laser coders have a life span of up to 12 years of production.

Improve uptime

Laser coding requires virtually no planned maintenance and is inherently more reliable than alternative coding technologies. **F-Series** lasers enable you to increase your manufacturing uptime significantly and help minimize your repair costs.

Reduce consumables

F-Series lasers do not require chemicals, solvents, or acids. **F-Series** lasers have an extraction system, which will need an occasional filter change. Consumables and related operational costs are reduced. The difference is significant.

Pulse Selector technology

A perfectly tuned laser for top-quality codes

F230i comes standard with Pulse Selector technology. It gives you the ability to choose between 40 waveforms, so your laser is tuned to perfection to your material. Precision tuning is key when marking many substrates, including dark plastics or multilayer flexible films.

Specific material selection

Fiber lasers are powerful tools which can mark a wide range of substrates with ease. **F230i** has two waveforms with a given peak power, pulse energy, and pulse repetition frequency. This means you will get high-quality coding results for a certain range of materials such as light plastics and some metals.

Extended material variety

F230i's Pulse Selector technology provides the ability to choose between 40 waveforms. This variety gives you greater control of the pulse conditions and therefore of how the laser is tuned to your material. You can achieve the best in terms of quality, productivity, and substrate protection for an extended variety of materials such as light and dark plastics, multilayer flexible films, and many kinds of metals.

Sample lab recommendation

Domino's sample lab will test and recommend the most suitable waveform for your various applications and substrates. To switch substrates, simply select the recommended option from your Pulse Selector library, eradicating any need for trial-and-error and reducing unnecessary product waste.

Pulse Selector technology in the **F230i**

Application-specific setting of the waveform

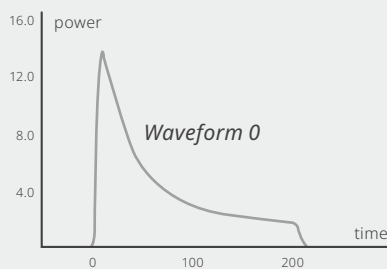

High power, long length

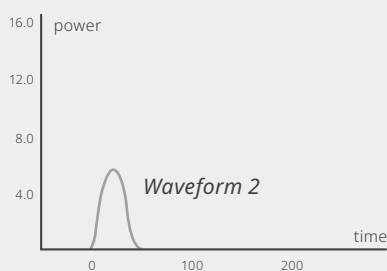

Low power, short length



Waveform 0 can be used for engraving which is ideal for metals



Waveform 2 creates a color change which is ideal for foils

Electronics

For housings, switches, power supply units, circuit boards, and many more

It's a small world

Electromechanical parts are getting smaller. The **F-Series** hyper sharp laser spot allows you to create ultra-fine precision codes on small components. You can mark at 150µm character height or a 14x14 Data Matrix code that is 1.2mm², all in high resolution with A-grade readability. **F-Series** lasers can even code complex messages with logos and graphics on small surface areas.



F-Series marks your molded plastic housings in high quantities.

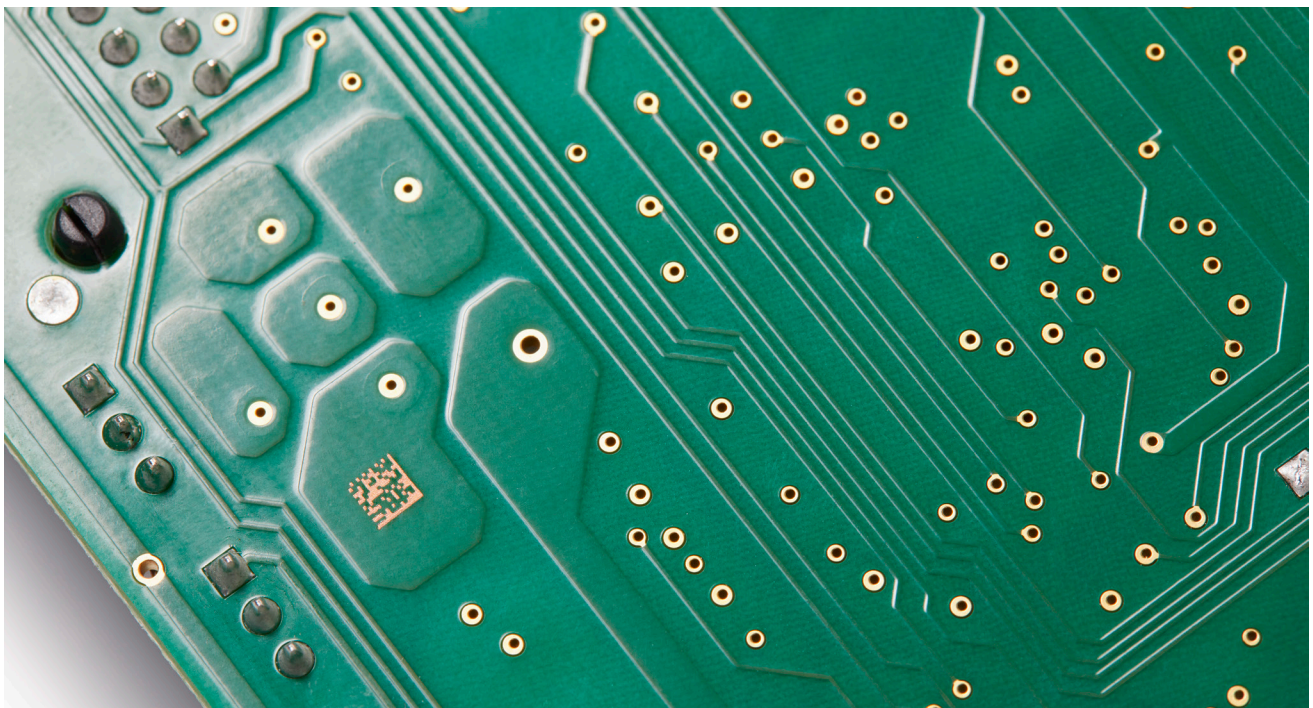

Add traceability to your PCB boards with 2D Data Matrix barcodes

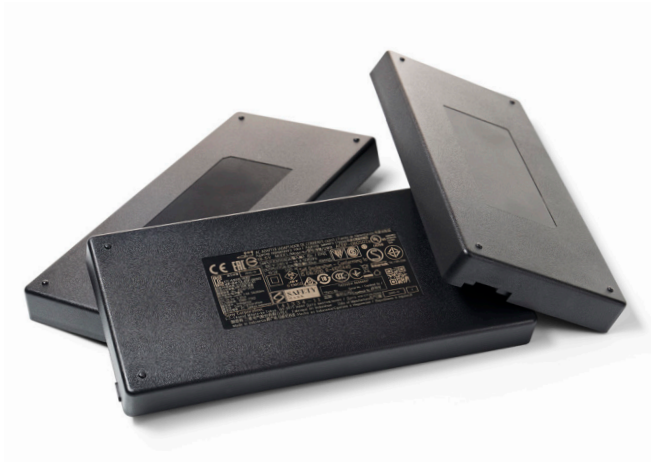

Sharp clear codes are achieved with a bleaching effect on dark plastics

High legibility through sharp coding

F-Series lasers create sharp, clear codes with excellent legibility. With an **F-Series** laser, you can create permanent human- and machine-readable codes, which are ideal for products with long and complex supply chains.

Maintain product integrity

Highly precise beam control ensures that **F-Series** lasers mark only where they are needed, without affecting other surrounding material or components.

Food

For a wide range of food applications, from flexible pouches and films for confectioners and fruit packers, to plastic pots and steel tins for dairy producers and food canners.

Coding on flexible film



Durable top-class coding

Codes on food products need to be indelible and resistant to abrasion or smearing that can cause poor readability. Poorly coded products typically need to be scrapped, causing waste and production losses.

By contrast, **F-Series** offers reliable coding with high-clarity, permanent codes that will last the full length of the product's lifetime. This means your line waste can be dramatically reduced and your equipment efficiency improved.

Respects material barriers

Perforation or damage of barrier properties can be a concern with some laser technologies, especially when coding delicate film packaging as the material can be easily penetrated. **F-Series** Pulse Selector technology provides the ability to select a waveform with a non-thermal effect. This means that your substrates' color is photochemically faded and the barrier properties remain completely unaffected.

Coding on steel tins



Full traceability

Ensure traceability of baby formula packs and give consumers confidence in the authenticity of your product. **F-Series** enables you to mark machine-readable codes for individual product traceability. The codes are permanent and can be applied at high speeds on cans of all different sizes.

Coding on plastic containers

For dairy producers

F-Series marks high-contrast and sleek laser codes directly onto plastic containers. Codes are produced by a photochemical color change, which doesn't affect the container's barrier properties. Because laser coding is a chemical-free technology it is ideal for aseptic packaging in a sterile environment.



Pharma

For pharmaceutical products and medical devices such as asthma cans, insulin pens, ampoules, and many more.



Get discreet, sleek codes on devices with frequent patient contact

Discreet codes

Patients are often in close contact with medical devices such as asthma inhalers. **F-Series** codes are sleek in design to ensure discreet placement of traceability information.



F-Series codes are permanent, even when in contact with hand sanitizers

IPA and alcohol resistant

Having indelible traceability on medical devices is crucial especially where the use of sanitizers and washes could cause codes to be removed. The laser code is permanent and withstands treatment with IPA and alcohol.

Ideal for sensitive environments

F-Series is ideal for sensitive environments, as it is a completely chemical-free technology.

Futureproof coding

Compared to other laser coders, the **F-Series** lens offers an exceptionally wide marking area. This means that you can code multiple products simultaneously, for fast throughput. The wide marking area also allows for the addition of more complex data, should regulations of coding requirements change.



Marking of clearly readable scale on plastic bottles



F-Series lasers mark even rounded surfaces

Industrial

For industrial parts and automotive applications such as pipes, saw blades, oil filters, breaking discs, sparking plugs, or license plates.

Resistant to heat and moisture

Ink-based coded metal parts can have issues with adhesion and permanence, especially when exposed to heat or chemicals, leading to costly product waste. Our **F-Series** is ideal for permanently marking metal parts with clear crisp codes. Codes can be applied in high-temperatures and wet processing environments, or where a product may be exposed to these conditions during assembly and use.



You can generate dark codes without engraving the metal by using an annealing effect

Coding anti-counterfeit elements

F-Series can code highly complex data with ease to ensure you can always identify counterfeit products. For example licence plates, which are laminated with laser sensitive foils, can be coded with anti-counterfeit elements such as elaborate watermarks.



Anti-counterfeit elements are coded on reflective foils with **F-Series**



F-Series marks many kinds of metals including steel, aluminium, titanium and brass

Adding permanent traceability information

F-Series allows you to mark your parts directly to enable complete traceability. **F-Series** codes are permanent and indelible, so they will remain on the product throughout its lifetime. They are nearly impossible to remove, so you can be sure that only authentic products will be returned back to you in the event of a recall.



F-Series codes are permanent even when exposed to heat or chemicals

Tobacco

For tobacco pouches and e-vapor products

Your partner in coding

No other company can compare to Domino's successful coding deployments to the tobacco sector. Domino has sold over 2500 lasers to the tobacco industry, and assists with coding trillions of packs per annum. **F-Series**, like all our laser products, is a proprietary Domino technology that benefits from our extensive expertise and heritage.

Serialization at high speeds

With **F-Series** you can use Codentify® or other serialization data format to code your products while keeping your production line running at high speed. You can mark your tobacco packaging with high-quality machine-readable codes such as Data Matrix and other barcodes without sacrificing your productivity.



Perfect readable codes on tobacco pouches made from polypropylene

A tobacco solution that's right for you

The small scanhead on the **F-Series** makes integration into OEM equipment easy and straightforward. Choose from over 100 application parts specifically designed for existing OEM tobacco lines and ensure your **F-Series** integration is efficient, fast, and safe. Get advanced vision systems for code verification, product handling, conveyor systems, and reject control, and benefit from a full tobacco solution package from a single supplier.

Complex codes, easily coded

Over the years, code formats for tobacco products have increased in complexity, particularly with the addition of machine-readable codes. With **F-Series** these large code formats (often with over 50 characters) can easily be printed at both high quality and high speed. Your codes will have strong contrast, excellent readability, and will always be in the right spot.



A full coding solution

SafeGuard

Protect your investment

An outstanding level of care, wherever you are. Our **SafeGuard** packages provide high-quality, on-site assistance, and augmented reality enabled remote guidance from our engineers. **SafeGuard** helps to ensure we can be with you when you need us most.

Domino Cloud

Smart production

Gain operational insight by connecting your printer to **Domino Cloud**. Obtain production analytics dashboards and receive system error alerts. **Domino Cloud** provides you with the information you need to run your operations more efficiently.

R-Series

Code inspection automated

Ensure every code that leaves your factory is present and correct, and free up operator time. With the **R-Series**, Domino's range of vision control systems, you can automate your code inspection to validate code presence, placement, and readability.

Automation

Centralize your label management: **Domino Automation** easily integrates into your manufacturing process as well as your ERP/MES systems. It makes automatic changeovers safe and simple, helping you to reduce waste and drive sustainability initiatives while increasing productivity and efficiency.

Value →



+



Operational support

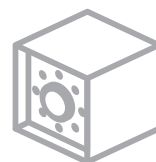

Automatic code inspection



Control software

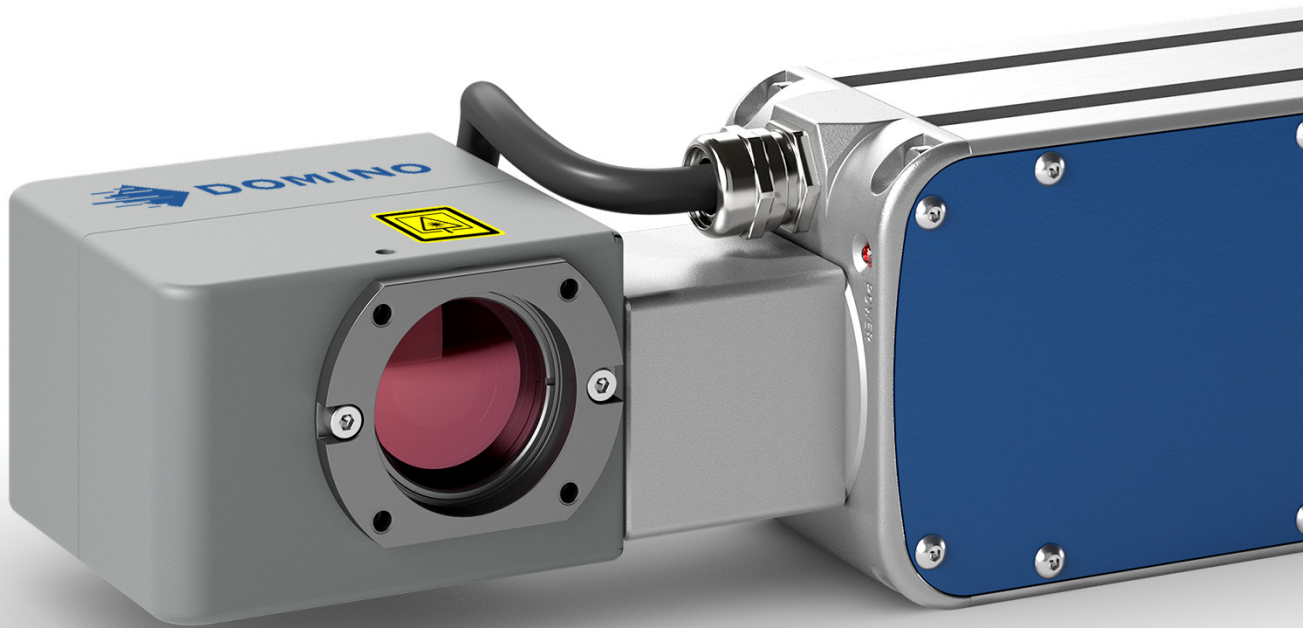

Your professional partner in coding

How can we help you?

Tell us what your coding problem is, and we will help you solve it. Our teams of in-house scientists, working all over the world, are available to test your substrate and determine the best laser solution for your requirements. This can be conducted virtually if you are unable to meet with our experts in person.

Open and responsive consultation

Domino has a broad coding technology portfolio and always recommends the best technology option for the customer. Each technology has advantages and any organization considering installing a coder will be guided by their trusted Domino consultant to identify the machine is right for their specific packaging and coding needs.

Safe and custom-fit integration

Domino's bespoke engineering services and unique guarding designs ensure that your laser installation will be safe and straightforward.

Technical specification

	F230i CP	F230i EP	F520i CP	F720i CP
Laser type	Pulsed fiber laser	Pulsed fiber laser with Pulse Selector	Pulsed fiber laser	Pulsed fiber laser
Selectable waveforms	2	40	2	2
Laser wavelength	1059-1065nm			
Laser power (maximum average output)	20W	20W	50W	70W
Laser source life time (MTBF)	100.000h			
Internal aiming	Wavelength: 630-670nm P _{max} =390μW Class 1 Laser Product		Wavelength: 630-670nm P _{max} =390μW Class 1 Laser Product	
Coding Features				
Coding speed	Supports high speed application.*			
Fonts and texts	Laser optimized fonts for high-speed marking incl. standard fonts, multi-language, and unicode.			
Graphics and logos	*.bmp (monochrome), *.plt, *.dxf			
Machine readable codes	More than 60 ID bar codes and 2 Data Matrix codes. Supporting GS1.			
Code content	Supporting traceability coding with serialization data. Configurable date, counter, and time format.			
Focal length/coding field	160mm/118x118mm, 250mm/187x187mm, 300mm/229x229mm			
Dimension, Wt, Integration				
Laserhead dimension	80x141x501mm			
Laserhead weight	30x471x308		405x430x560	
Controller dimension (LxWxH)	405x430x680 (water cooled with optional heat exchange module)			
Controller weight	37.6kg		40.5kg Water cooled: 49kg	43kg Water cooled: 51.5kg
Fiber length	2.7m -bending radius 75mm			
Integration	i-Tech scan head. Customizable integration through various scan head orientations.			
Environment				
Operating temperature	5 - 40°C		5 - 35°C (up to 45°C optional with water cooling)	
Humidity	Max. 90% RH, non-condensing			
Ingress protection laser head	IP65			
Ingress protection controller	IP43 (air cooled)		IIP55 air cooled (IP65 optional with water cooling)	
Power requirements	100 - 240VAC, 50/60Hz			
Power consumption	max. 3.5A/350VA		max. 5.3A/500VA	
User Interface and Software				
User interface	Graphical user interface, WYSIWYG entry, TouchPanel (optional) Control language is configurable in over 25 languages.			
Marking software	QuickStep2 including Dynamark4			
Inputs and Outputs, Interfaces				
Product detect inputs	NPN/PNP/24V – sensor			
Product speed detect	Shaft encoder (differential) or steady signal (single-ended signal)			
Signal inputs/outputs	Multiple inputs and outputs available from controller e.g. fume extractor, compressed air-kit, water chiller, encoder, product detect, beacon and interlocks. Output signals provided for coder ready, coder busy, compile ok and coding done. Additional inputs available for laser start, coding control and programmable logic.			
Interfaces	USB, RS232, EtherNet (10/100 Mbit), EtherNet/IP™ (optional)			
Options and Accessories				
Options	User port kit I/O, shutter, connecting cable kit (4.5m, 9m), USB image backup/restore kit, 4-color beacon, velocity kit, door lock, pharma option		User port kit I/O, USB image backup/restore kit, 4-color beacon, heat exchange module. (IP65 options: chiller / factory water), pharma option	
Accessories	Rack mounting kit, laser stand, fume extraction system		Laser stand, fume extraction system	
Application Certificate				
Marking: CE,** cTUVus / Fulfills requirement: ROHS, FDA listed, EMC, FCC				

*Substrate, pitch and code dependent. Please consult your account manager

**Partly Completed Machinery as per Machinery Directive (2006/42/EC), CE marking according to ROHS (2011/65/EU) and EMC (2014/30/EU).

EtherNet/IP™
ODVA

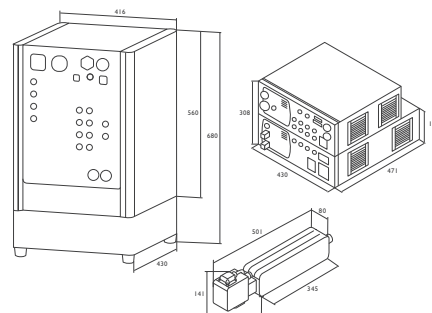

TALK TO AN EXPERT

800.444.4512

solutions@domino-na.com

www.domino-na.com/contact